



TC-512

OPERATOR'S MANUAL

Issue 1.

Date of issue:

1st August 2003

® The Techne logo is the trademark
of Techne and Techne Inc.

© Techne, 2003

Contents

TC-512 Operator's Manual

	<i>page</i>
SAFETY AND INSTALLATION	
Declaration of conformity	3
English	4
Français	5
Deutsch	6
Español	7
THE TC-512	8
Warning	8
Unpacking	8
Typical specification at an ambient of 20°C	9
Working conditions	10
Uses of the Touchgene	10
Tubes or reaction vessel	10
Cleaning your TC-512	11
Block removal	11
The heated lid	12
The memory card	13
Adjusting the light intensity of the screen	13
Before switching on	14
Connections on the back of the unit	14
Symbols on the screen	14
Connecting one unit to the computer using an RS232 Cable	15
Connecting several units to the computer using the daisy chain cables	15
Some frequently asked questions	16
POWER UP SCREENS	17
System user main menu	18
Program defaults	18
Numerical input screen	19
PROGRAMS	20
New program screen	20
Template program screens	21
Existing program screen	23
Editing programs	24
The TC-512	28
Increment or decrement temperature or time	30
'Save' before 'Run'	31
RUNNING A PROGRAM	32
While running programs	33
Data logs	34
Printing Data logs	34
Using "Gensoft"	36
ADDITIONAL INFORMATION	37
Interchangeable blocks	38
Accessories	39
Replacement parts	39

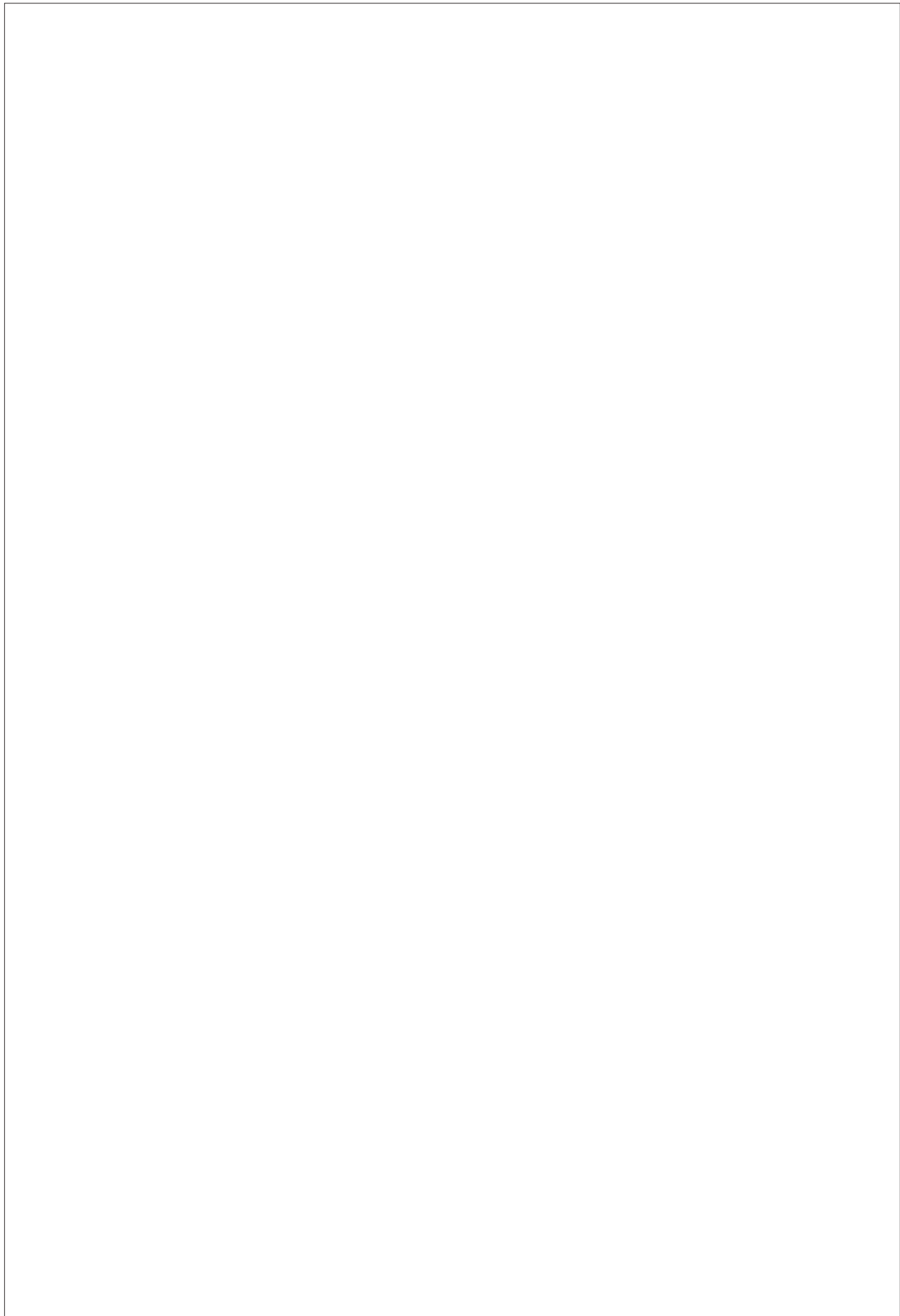



Techne
Duxford
Cambridge
CB2 4PZ



Declaration of Conformity

Techne Unit TC-512 has been designed to comply with the following European Standards:

EN 61326:1998 Electrical equipment for measurement, control and laboratory use. EMC requirements.

EN 61010-1:1993 Safety requirements for electrical equipment for measurement, control and laboratory use.

EN 61010-2-010:1995 Particular requirements for laboratory equipment for the heating of materials.

I have made all reasonable enquiries regarding the unit stated and its conformance to the following EU directives:

Low Voltage directive, 73/23/EEC and amendment 93/68/EEC, and

EMC Directive 89/336/EEC and amendments 91/263/EEC 92/31/EEC and 93/68/EEC.

To the best of my knowledge and belief these units conform to these directives.

This Declaration is controlled under an ISO 9001:2000 system certificated by BSI Quality Assurance, certificate number FM13585.

Signature

Name

B C Coombes

Position

Quality Manager

Issue 1

01/08/2003

Introduction

Please read all the information in this booklet before using the unit.

Warning

 **HIGH TEMPERATURES ARE DANGEROUS:** they can cause serious burns to operators and ignite combustible material.

Techne have taken great care in the design of these units to protect operators from hazards, but users should pay attention to the following points:

- USE CARE AND WEAR PROTECTIVE GLOVES TO PROTECT HANDS;
- DO NOT put hot objects on or near combustible objects;
- DO NOT operate the unit close to inflammable liquids or gases;
- DO NOT place any liquid directly in your unit;
- At all times USE COMMON SENSE.

Operator Safety

All users of Techne equipment must have available the relevant literature needed to ensure their safety.

It is important that only suitably trained personnel operate this equipment, in accordance with the instructions contained in this manual and with general safety standards and procedures. If the equipment is used in a manner not specified by Techne the protection provided by the equipment to the user may be impaired.

All Techne units have been designed to conform to international safety requirements and are fitted with an overtemperature cut-out. On some models, the cut-out is adjustable and should be set to suit the application. On all other models the cut-out is preset to protect the unit.

If a safety problem should be encountered, switch off at the mains socket and remove the plug from the supply.

Installation

1. All Techne units are supplied with a power cable. This may be integral or plug-in.
2. Before connecting the mains supply, check the voltage against the rating plate. Connect the mains cable to a suitable plug according to the table below. **Note that the unit must be earthed to ensure proper electrical safety.**

<i>Connections</i>	<i>220/240V</i>	<i>110/120V</i>
Live	Brown	Black
Neutral	Blue	White
Earth	Green/yellow	Green

The fused plug supplied with the mains lead for use in the UK is fitted with the following value fuse to protect the cable:

230V UK	10 AMP
---------	--------

The fuse in the unit protects the unit and the operator. Note that units marked 230V on the rating plate work at 220V; units marked 120V work at 110V. In both cases, however, the heating rate will degrade by approximately 8%. The rating plate is on the rear of the unit.

3. Plug the mains cable into the socket on the rear of the unit.
4. Place the unit on a suitable bench or flat workspace, or in a fume cupboard if required, ensuring that the air inlet vents on the underside are free from obstruction.
5. Symbols on or near the power switch of the unit have the following meanings:
 - I : mains switch On
 - O : mains switch Off

After use

When you have finished heating samples, remember that parts of the unit – the tubes, blocks and associated accessories – may be very hot. Take the precautions listed earlier.

Guarantee

The unit is guaranteed against any defect in material or workmanship for the period specified on the enclosed guarantee card. This period is from the date of purchase, and within this period all defective parts will be replaced free of charge provided that the defect is not the result of misuse, accident or negligence. Servicing under this guarantee should be obtained from the supplier.

Notwithstanding the description and specification(s) of the units contained in the Operator's Manual, Techne hereby reserves the right to make such changes as it sees fit to the units or to any component of the units.

This Manual has been prepared solely for the convenience of Techne customers and nothing in this Instruction Book shall be taken as a warranty, condition or representation concerning the description, merchantability, fitness for purpose or otherwise of the units or components.

User maintenance

NOTE THAT THIS EQUIPMENT SHOULD ONLY BE DISMANTLED BY PROPERLY TRAINED PERSONNEL. REMOVING THE SIDE, FRONT OR REAR PANELS EXPOSES POTENTIALLY LETHAL MAINS VOLTAGES. THERE ARE NO USER MAINTAINABLE PARTS WITHIN THE EQUIPMENT.

In the unlikely event that you experience any problems with your unit which cannot easily be remedied, you should contact your supplier and return the unit if necessary. Please include any details of the fault observed and remember to return the unit in its original packing. Techne accept no responsibility for damage to units which are not properly packed for shipping: if in doubt, contact your supplier. See the De-contamination Certificate supplied with your unit.

1. Cleaning

Before cleaning your unit ALWAYS disconnect from the power supply and allow to cool below 50° C. Your unit can be cleaned by wiping with a damp soapy cloth. Care should be exercised to prevent water from running inside the unit. Do not use abrasive cleaners.

2. Fuses

Your unit is protected by one or two fuses. These should only be changed by suitably qualified personnel. If the fuses blow persistently, a serious fault is indicated and you may need to return the unit to your supplier for repair.

Contact Information

For technical, sales or servicing information, contact your local Techne dealer or,
 Techne, Duxford,
 Cambridge, CB2 4PZ, United Kingdom.
 Telephone: +44(0)1223 832401
 Fax: +44(0)1223 836838
 Service: +44(0)1223 836950 Out of office hours
 e-mail: sales@techne.com
 Web site: www.techne.com

or,
 Techne Inc, 3 Terri Lane,
 Suite 10, Burlington,
 New Jersey 08016, USA.
 Telephone: 609-589-2560
 Toll free: 800-225-9243 ext 306
 Fax: 609-589-2571
 e-mail: labproducts@techneusa.com
 Web site: www.techneusa.com

Introduction

Veillez lire attentivement toutes les instructions de ce document avant d'utiliser l'appareil.

Avertissement



DANGER DE TEMPERATURES ELEVEES : les opérateurs peuvent subir de graves brûlures et les matériaux combustibles risquent de prendre feu.

Techne a apporté un soin tout particulier à la conception de ces appareils de façon à assurer une protection maximale des opérateurs, mais il est recommandé aux utilisateurs de porter une attention spéciale aux points suivants:

- **PROCEDER AVEC SOIN ET PORTER DES GANTS POUR SE PROTEGER LES MAINS.**
- **NE PAS** poser d'objets chauds sur ou près de matériaux combustibles.
- **NE PAS** utiliser l'appareil à proximité de liquides ou de gaz inflammables.
- **NE PAS** verser de liquide directement dans l'appareil.
- **FAIRE TOUJOURS PREUVE DE BON SENS.**

Sécurité de l'opérateur

Tous les utilisateurs de produits Techne doivent avoir pris connaissance des manuels et instructions nécessaires à la garantie de leur sécurité.

Important : cet appareil doit impérativement être manipulé par un personnel qualifié et utilisé selon les instructions données dans ce document, en accord avec les normes et procédures de sécurité générales. Dans le cas où cet appareil ne serait pas utilisé selon les consignes précisées par Techne, la protection pour l'utilisateur ne serait alors plus garantie.

Tous les appareils Techne sont conçus pour répondre aux normes de sécurité internationales et sont dotés d'un coupe-circuit en cas d'excès de température. Sur certains modèles, ce coupe-circuit est réglable pour s'adapter à l'application désirée. Sur d'autres modèles, il est pré-réglée en usine pour assurer la protection de l'appareil.

Dans le cas d'un problème de sécurité, coupez l'alimentation électrique au niveau de la prise murale et enlevez la prise connectée à l'appareil.

Installation

1. Tous les appareils Techne sont livrés avec un câble d'alimentation qui peut être intégré à l'appareil ou à raccorder.
2. Avant de brancher l'appareil, vérifiez la tension requise indiquée sur la plaque d'identification. Raccordez le câble électrique à la prise appropriée en vous reportant au tableau ci-dessous. **Il est important que l'appareil soit relié à la terre pour assurer la protection électrique requise.**

Connexions	220/240 V	110/120 V
Phase	Marron	Noir
Neutre	Blue	Blanc
Terre	Vert/juane	Vert

Le fusible à l'intérieur de l'appareil est destiné à assurer la protection de l'appareil et de l'opérateur.

Remarque : les appareils dont la plaque indique 230 V peuvent fonctionner sur 220 V, et ceux dont la plaque indique 120 V peuvent fonctionner sur 110 V. Dans les deux cas cependant, le capacité de chauffage diminuera d'environ 8 %. La plaque d'identification se trouve à l'arrière de l'appareil.

3. Raccordez le câble d'alimentation à la prise située à l'arrière de l'appareil.
4. Placez l'appareil sur un plan de travail ou surface plane, ou le cas échéant, dans une hotte d'aspiration, en s'assurant que les trous d'aération situés sous l'appareil ne sont pas obstrués.
5. Les symboles situés sur ou à côté de l'interrupteur de l'appareil ont la signification suivante :
 - : arrêt
 - I : marche

Après utilisation

Lorsque vous avez fini de chauffer les échantillons, n'oubliez pas que certaines parties de l'appareil - les éprouvettes, leurs supports et autres accessoires - risquent d'être très chaudes. Il est donc recommandé de toujours prendre les précautions citées plus haut.

Garantie

L'appareil est garanti contre tout défaut ou vice de fabrication pour la durée figurant sur la carte de garantie, à compter de la date d'achat de l'appareil. Au cours de cette période, toutes les pièces défectueuses seront remplacées gratuitement, dans la mesure où la défaillance n'est pas due à une mauvaise utilisation, un accident ou une négligence. Toute réparation sous garantie sera effectuée par le fournisseur.

Malgré la description et les spécifications de l'appareil données dans le manuel de l'utilisateur, Techne se réserve le droit d'effectuer les changements nécessaires à l'appareil ou à tout élément qui entre dans sa composition.

Ce manuel a été exclusivement rédigé à l'attention des clients de Techne, et aucun élément de ce guide d'instructions ne peut être utilisé comme garantie, condition ou représentation concernant la description, commercialisation, adaptation aux conditions d'utilisation ou autre des appareils ou de leurs composants.

Entretien utilisateur

IMPORTANT : CET APPAREIL NE PEUT ETRE DEMONTE QUE PAR DU PERSONNEL QUALIFIE.

LORSQUE LES PANNEAUX AVANT, ARRIERE ET LATERAUX SONT DEMONTES, L'OPERATEUR EST EXPOSE A DES TENSIONS QUI PEUVENT ETRE MORTELLES.

CET APPAREIL NE CONTIENT AUCUN ELEMENT QUI DEMANDE UN ENTRETIEN DE LA PART DE L'UTILISATEUR.

Dans le cas peu probable où votre appareil présente un défaut de fonctionnement auquel il est difficile de remédier, il est alors préférable de contacter votre fournisseur et, le cas échéant, de renvoyer le matériel. Veuillez inclure une description détaillée du problème constaté et retourner l'appareil dans son emballage d'origine. Techne ne sera pas tenu responsable des dommages subis par tout appareil dont l'emballage est inadéquat pour le transport. Pour plus de sûreté, contactez votre fournisseur. Voir le certificat de décontamination livré avec le produit.

1. Nettoyage

Avant de nettoyer l'appareil, assurez-vous TOUJOURS que le câble d'alimentation est déconnecté et laissez la température redescendre en dessous de 50 °C.

Utilisez un chiffon imprégné d'eau savonneuse pour nettoyer l'appareil. Veillez à ne pas introduire d'eau dans l'appareil. N'utilisez pas de produits abrasifs.

2. Fusibles

La protection de l'appareil est assurée par un ou deux fusibles dont le remplacement ne peut être effectué que par un personnel qualifié.

Si les fusibles sautent sans arrêt, il s'agit d'un problème sérieux. Nous vous conseillons dans ce cas de prendre contact avec votre fournisseur pour réparation.

Einleitung

Bitte lesen Sie diese Bedienungsanleitung komplett bevor Sie dieses Gerät benutzen.

Warnung

 **HOHE TEMPERATUREN SIND GEFÄHRLICH:** sie können dem Bediener ernsthafte Verletzungen zufügen und brennbare Materialien können sich leicht entzünden.

Techne hat bei der Konstruktion dieses Gerätes sehr darauf geachtet, daß der Bediener vor Gefahren geschützt ist. Dennoch sollten Sie auf die folgenden Punkte achten:

- SEIEN SIE VORSICHTIG UND TRAGEN SIE SCHUTZHANDSCHUHE
- Legen Sie heiße Gegenstände NICHT auf oder in die Nähe von leicht brennbaren Materialien; vermeiden Sie Arbeiten in der Nähe von leicht entzündbaren Flüssigkeiten oder Gasen.
- Bringen sie KEINE Flüssigkeiten direkt in Ihr Gerät.
- Benutzen Sie immer den normalen Menschenverstand

Sicherheit des Anwenders

Alle Benutzer von Techne Geräten müssen Zugang zu der entsprechenden Literatur haben, um ihre Sicherheit zu gewähren.

Es ist wichtig, daß diese Geräte nur von entsprechend geschultem Personal betrieben werden, das die in dieser Gebrauchsanweisung enthaltenen Maßnahmen und allgemeine Sicherheitsbestimmungen und -vorkehrungen beachtet. Wenn das Gerät anders eingesetzt wird als vom Hersteller empfohlen, kann dies die persönliche Sicherheit des Anwenders beeinträchtigen. Die Geräte von Techne entsprechen den internationalen Sicherheitsbestimmungen und sind mit einem automatischen Übertemperaturabschalter ausgestattet. Bei einigen Modellen ist der Übertemperaturabschalter verstellbar und sollte je nach Anwendung entsprechend eingestellt werden. Bei allen anderen Modellen ist der Temperaturschutz voreingestellt um Schäden am Gerät zu vermeiden. Wenn ein Sicherheitsproblem auftreten sollte, muß das Gerät ausgeschaltet und vom Stromnetz getrennt werden.

Installation

1. Alle Techne Geräte werden mit einem Stromanschlußkabel geliefert. Dieses ist entweder fest mit dem Gerät verbunden oder zum Einstecken.
 2. Vergleichen Sie, ob die Spannung Ihrer Stromversorgung mit den Angaben auf dem Typenschild des Geräte übereinstimmen. Verbinden Sie das Stromanschlußkabel mit einer geeigneten Stromversorgung gemäß der nächstehenden Tabelle. Achtung: Das Gerät muß geerdet sein, um die elektrische Sicherheit zu gewährleisten!
- | | | |
|--------------|-----------|----------|
| Verbindungen | 220/240V | 110/120V |
| Stromführend | Braun | Schwarz |
| Neutral | Blau | Weiß |
| Erde | Grün/Gelb | Grün |
- Geräte, die für 230 Volt ausgelegt sind, können auch bei 220 Volt arbeiten, Geräte für 120 Volt auch bei 110 Volt. In beiden Fällen verringert sich die Aufheizrate um ca. 8%. Das Typenschild befindet sich hinten am Gerät.
3. Stecken Sie das Stromkabel in die vorgesehene Buchse hinten am Gerät.
 4. Stellen Sie das Gerät auf eine ebene Arbeitsfläche bzw. (falls erforderlich) unter einen Laborabzug. Beachten Sie, daß die Entlüftungsrillen an der Geräteunterseite immer frei zugänglich sind.
 5. Die Symbole auf oder neben dem EIN/AUS-Schalter an der Geräterückseite bedeuten:

- I : An
- O : Aus

Nach dem Gebrauch

Vergessen Sie nicht, daß Teile des Gerätes (die Gefäße, die Blöcke und andere Zubehörteile) nach dem Erhitzen von Proben noch sehr heiß sein können. Bitte beachten Sie die oben genannten Vorsichtsmaßnahmen.

Garantie

Die Garantiedauer des Gerätes ist auf der beiliegenden Garantiekarte angegeben und schließt Fehler im Material oder der Verarbeitung ein. Die Garantiedauer beginnt am Tag des Einkaufs. Sämtliche defekte Teile werden innerhalb dieses Zeitraumes kostenlos ersetzt unter der Voraussetzung, daß dem Defekt keine unsachgemäße Handhabung, Fahrlässigkeit oder ein Unfall zugrundeliegt. Der unter diese Garantie fallende Service wird vom Lieferanten geleistet.

Ungeachtet der in dieser Gebrauchsanweisung enthaltenen Beschreibungen und Spezifikationen, behält sich Techne hiermit das Recht vor, Änderungen an den Geräten bzw. an einzelnen Geräteteilen durchzuführen.

Diese Gebrauchsanleitung wurde ausschließlich dazu erstellt, um Kunden die Handhabung der Techne-Geräte zu erleichtern. Nichts in dieser Gebrauchsanleitung darf als Garantie, Bedingung oder Voraussetzung verstanden werden, sei es die Beschreibung, Marktgängigkeit, Zweckdienlichkeit oder sonstiges bezüglich der Geräte oder deren Bestandteile.

Wartung durch den Bediener

BEACHTEN SIE, DASS DIESES GERÄT NUR VON TECHNISCHEN FACHKRÄFTEN GEÖFFNET UND DEMONTIERT WERDEN DARF.

DURCH ENTFERNEN DES GEHÄUSES ODER GEHÄUSETEILEN SIND BAUTEILE MIT LEBENGEFÄHRLICHEN SPANNUNGEN FREI ZUGÄNGLICH.

IM INNERN DES GERÄTES BEFINDEN SICH KEINE TEILE, DIE VOM ANWENDER GEWARTET WERDEN MÜSSEN.

Falls Ihr Gerät nicht ordnungsgemäß arbeitet, wenden Sie sich an Ihren Lieferanten oder senden Sie das Gerät wenn nötig zurück. Fügen Sie eine genaue Beschreibung des Defektes bei. Verpacken Sie das Gerät möglichst im Originalkarton. Bitte beachten Sie, daß Techne keine Haftung bei Transportschäden aufgrund unzureichender Verpackung übernehmen. Setzen Sie sich im Zweifelsfall mit Ihrem Lieferanten in Verbindung. Bitte beachten Sie die Entgiftungsbescheinigung, die Sie mit dem Gerät erhalten haben.

1. Reinigen

Bevor Sie Ihr Gerät reinigen, sollten Sie

- zuerst den Netzstecker ziehen
- das Gerät unter 50°C abkühlen lassen.

Ein feuchtes Tuch mit Seifenlösung reinigt Ihr Gerät am besten. Achten Sie darauf, daß kein Wasser in das Gerät gelangt. Verwenden Sie keine Scheuermittel.

2. Sicherungen

Die Stromzuleitung ist durch ein oder zwei Sicherungen geschützt. Diese sollten nur durch qualifiziertes Fachpersonal ausgetauscht werden. Wenn die Sicherung wiederholt durchbrennt, liegt ein größerer Defekt vor. Das Gerät muß zur Reparatur an Ihren Lieferanten eingesandt werden.

Introducción

Le rogamos lea cuidadosamente la información contenida en este folleto antes de manipular el aparato.

Aviso



LAS TEMPERATURAS ELEVADAS SON PELIGROSAS: pueden causarle graves quemaduras y provocar fuego en materiales combustibles.

Techne ha puesto gran cuidado en el diseño de estos aparatos para proteger al usuario de cualquier peligro; aún así se deberá prestar atención a los siguientes puntos:

- **EXTREME LAS PRECAUCIONES Y UTILICE GUANTES PARA PROTEGERSE LAS MANOS;**
- NO coloque objetos calientes encima o cerca de objetos combustibles;
- NO maneje el aparato cerca de líquidos inflamables o gases;
- NO introduzca ningún líquido directamente en el aparato;
- **UTILICE EL SENTIDO COMUN** en todo momento.

Seguridad del usuario

Todos los usuarios de equipos Techne deben disponer de la información necesaria para asegurar su seguridad.

De acuerdo con las instrucciones contenidas en este manual y con las normas y procedimientos generales de seguridad, es muy importante que sólo personal debidamente capacitado opere estos aparatos. De no ser así, la protección que el equipo le proporciona al usuario puede verse reducida.

Todos los equipos Techne han sido diseñados para cumplir con los requisitos internacionales de seguridad y traen incorporados un sistema de desconexión en caso de sobretemperatura. En algunos modelos el sistema de desconexión es variable, lo que le permite elegir la temperatura según sus necesidades. En otros, el sistema de desconexión viene ya ajustado para evitar daños en el equipo. En caso de que surgiera un problema de seguridad, desconecte el equipo de la red.

Instalación

1. Todos los aparatos Techne se suministran con un cable de alimentación. Puede ser fijo o independiente del aparato.
2. Antes de conectarlo, compruebe que el voltaje corresponde al de la placa indicadora. Conecte el cable de alimentación a un enchufe adecuado según la tabla expuesta a continuación. El equipo debe estar conectado a tierra para garantizar la seguridad eléctrica.

<i>Conexiones</i>	220/240V	110/120V
Linea	Marrón	Negro
Neutro	Azul	Blanco
Tierra	Verde/amarillo	Verde

El fusible una vez instalado protege tanto al equipo como al usuario.

Asegúrese de que los equipos marcados 230V en la placa indicadora funcionan a 220V y de que los equipos marcados 120V funcionan a 110V. No obstante, en ambos casos la velocidad de calentamiento se verá reducida en un 8% aproximadamente. La placa indicadora está situada en la parte posterior del equipo.

3. Conecte el cable a la toma de tensión en la parte posterior del equipo.
4. Sitúe el aparato en un lugar apropiado tal como una superficie de trabajo plana, o si fuera necesario incluso en una campana con extractor de humos, asegurándose de que las entradas de aire en la parte inferior no queden obstruidas.
5. Los símbolos que se encuentran en o cerca del interruptor de alimentación tienen los siguientes significados:
 - I : Interruptor principal encendido
 - O : Interruptor principal apagado

Después de su uso

Cuando haya finalizado el calentamiento de muestras, recuerde que las piezas del equipo, tales como tubos, bloques y demás accesorios, pueden estar muy calientes. Tome las precauciones mencionadas anteriormente.

Garantía

Este aparato está garantizado contra cualquier defecto material o de fabricación durante el periodo especificado en la tarjeta de garantía adjunta. Este plazo inicia a partir de la fecha de compra, y dentro de este periodo todas las piezas defectuosas serán reemplazadas gratuitamente siempre que el defecto no sea resultado de un uso incorrecto, accidente o negligencia. Mientras se encuentre bajo garantía las revisiones las debe llevar a cabo el proveedor.

A pesar de la descripción y las especificaciones de los aparatos contenidas en el Manual del Usuario, Techne se reserva por medio de este documento el derecho a efectuar los cambios que estime oportunos tanto en los aparatos como en cualquier componente de los mismos.

Este manual ha sido preparado exclusivamente para los clientes de Techne y nada de lo especificado en este folleto de instrucciones se tomará como una garantía, condición o aseveración de la descripción, comerciabilidad o adecuación para cualquier fin específico de los aparatos o sus componentes.

Mantenimiento

ESTE APARATO DEBE SER DESMONTADO SOLO Y EXCLUSIVAMENTE POR PERSONAL DEBIDAMENTE CAPACITADO.

EL RETIRAR LOS PANELES LATERALES, FRONTALES O TRASEROS SUPONE DEJAR AL DESCUBIERTO TENSION DE LA RED PELIGROSA.

EL EQUIPO NO CONSTA DE NINGUNA PIEZA DE CUYO MANTENIMIENTO SE PUEDA ENCARGAR EL USUARIO.

En el caso improbable de que experimentara algún problema con su aparato que no pudiera resolver con facilidad, debería ponerse en contacto con su proveedor y devolverlo si fuera necesario. Indique de forma detallada todos los defectos que haya notado y devuelva el equipo en su embalaje original. Techne no aceptará responsabilidad alguna por daños causados en equipos que no estuvieran debidamente embalados para su envío; si tuviera alguna duda, póngase en contacto con su proveedor. Sírvase consultar el Certificado de Descontaminación suministrado con su aparato.

1. Limpieza

Antes de limpiar su aparato, desconéctelo SIEMPRE de la fuente de alimentación y permita que se enfríe por debajo de los 50°C.

Este aparato se puede limpiar pasándole un paño húmedo enjabonado. Hágalo con cuidado para evitar que caiga agua dentro del mismo. No utilice limpiadores abrasivos.

2. Fusibles

Su aparato está protegido por uno o dos fusibles. Sólo deben cambiarlos personal debidamente capacitado.

Si los fusibles se fundieran repetidamente, esto indicaría una avería grave y puede que tuviera que devolverle el aparato a su proveedor para su reparación.

The TC-512

Before using the TC-512 make sure you have read this manual carefully. If there is any doubt relating to the proper use of this equipment, the staff at Techne or your supplier will be pleased to assist you.

The TC-512 provides the researcher with the means of accurately controlling the temperature profile of samples. It has many scientific applications, including DNA amplification and sequencing. The TC-512 can cycle samples between 4°C (39°F) and 99°C (210°F).

The TC-512 is programmed by means of a touch sensitive LCD graphics screen. Operator input temperatures are temperatures which you require the sample to achieve. Displayed temperatures can be the temperatures measured by the block probe or the calculated sample temperature or both. Profile data is saved in plug in memory cards, the program information is duplicated with the profile data log, and so the original programs are not required during analysis. A limited number of programs and all system settings are stored in nonvolatile memory within the TC-512. Additional programs may be stored in the nonvolatile memory cards, which are plugged into a slot under the cover above the screen.

A programme, which can be recalled from memory, consists of:

- a series of specified temperatures in °C
- the times for which each specified temperature will be held (Hold Times)
- the desired heating or cooling rates, in °C/min, between each specified temperature
- whether the times and/or the temperatures are to increase or decrease when a programme is repeated.

The memory card can store up to 500 three segment programs; the number of programs is reduced as the number of segments in each program is increased. The maximum is one program of 1500 segments.



Warning !

Please note that the touch screen on the TC-512 is easily damaged by sharp objects such as pens, pencils and fingernails. Damage of this sort will be considered as misuse and will invalidate the guarantee on this component.

Position the unit so that the mains on/off switch is accessible. If a safety problem should be encountered, switch off at the mains socket and remove the plug from the supply.

If you are using more than one unit in close proximity to each other, there must be at least 100mm between the units to allow the cooling air to flow from them.

Unpacking

When unpacking the unit, check that the following have been removed from the packing:

- The TC-512 unit with memory card in place
- Mains cable • Guarantee card • Decontamination Certificate

Keep the original packing, in case you ever need to return it for service or repair. Techne accepts no responsibility for damage incurred unless the unit is correctly packed and transported in its original packing.

Typical specification at an ambient of 20°C

For a detailed specification please contact Techne Sales

Temperature

TC-512 Range	20°C to 70°C
Maximum TC-512	30°C
Minimum TC-512	1°C
Number of temperature probes	4
Block temperature range	4°C to 99°C
Typical heat up rate	3.0°C/sec
Typical Cool down rate	1.3°C/sec
Block uniformity (without TC-512)	< ±0.4°C
Column uniformity with a 10°C TC-512	< ±0.3°C
Control accuracy	< ±0.3°C
TC-512 accuracy	< ±0.3°C
Temperature set point adjustment	±0.1°C

Integral Heated Lid

The heated lid only comes on if the block temperature is set above 30°C

Selectable heated lid temperature	100°C to 115°C
Heated lid enable/disable	Yes
Warm up time from ambient to 105°C	4 min
Over temperature cutout	Yes
Regulated lid pressure	Yes

Programs

Password protected	Yes
Incremental/decremental Segment Hold Time	-99 to +99sec, 1sec intervals
Incremental/decremental Temperature	-5.5°C to +5.6°C in 0.1°C intervals
Variable programmable ramp rate steps	±0.1°C/sec
Programmable ramp rate resolution	0.1°C
TC-512 calculator	Yes
Maximum programs internal memory	84 (dependant upon program complexity)
Maximum number of segments per loop	More than 60

Maximum number of loops per program	30
Maximum programs memory card	500 x 3 segment
Program naming capacity	Alpha/numeric
Program interface screen	Touch sensitive
Pause facility	Yes
End of program alarm (can be disabled)	Yes
Auto restart on power failure	Yes
Run end time calculation	Yes

Miscellaneous

Height x Width x Length	260 mm x 220 mm x 420 mm
Weight	12.5 kg
Power consumption	620W total including the heated lid
Parallel port	Yes
Serial Port RS232/RS485 adaptable	Yes
Connection to PC control program	Yes

Voltage

See page 14 for setting the voltage.

The units marked 100V will work at any voltage between 90V and 110V.

The units set to 120V will work at any voltage between 110V and 130V.

The units set to 230V will work at any voltage between 210V and 260V.

However, the performance may not meet the above specification at the extremes of voltage.

Working conditions

The TC-512 is designed to work safely under the following conditions:

Ambient temperature range 5°C to 40°C

Humidity Up to 95% relative humidity, non-condensing

Note:The control specifications are quoted at an ambient temperature of 20°C.

The specification may deteriorate outside an ambient temperature range of 10°C to 30°C.

Radio frequency interference tested and passed to EN50081-1.

Immunity Tested and passed to EN50082-1

Uses of the TC-512

The TC-512 has many scientific laboratory applications, including DNA sequencing and PCR. Aspects of the PCR process are claimed in U.S. Patent Nos. 4,683,195, 4,683,202, and 4,965,188. Use of the TC-512 in such processes does not convey a licence to practice the processes themselves.

Tubes or reaction vessel

Technique does not recommend any specific tube or reaction vessel other than those described in this Manual. We recommend using reaction volumes between 10 and 50µl. The tubes must withstand a pressure of 1 atmosphere at 100°C. Any vessel must be able to withstand the temperatures you are using without any danger of them deforming to the point where they fracture.

To test your tubes, put 25µl of water in each of 5 tubes and subject them to a typical thermal cycling protocol. At the end of the cycle, measure the volume remaining, using a micropipet. A loss of more than 1 or 2µl indicates a vapour leak.

The amount of volume loss you observe and the change in reactant concentrations you can tolerate determine the minimum volume that can be used. Typical volume losses of 1µl in 30 cycles allow the use of samples of 10µl or less.

During the final cooldown, a ring of condensation may form above the liquid level but below the top of the sample block. This is not usually a cause for concern, as the condensation does not form during cycling.

Cleaning your TC-512

Disconnect your unit from the power supply and allow it to cool to below 50°C before cleaning it.

The heat/cool block, including wells and flat surfaces, should be cleaned regularly to ensure optimum heat transfer to the samples. Always clean the block if there has been a spillage. Use a cloth or cotton buds dipped in a fresh, 50:50 water/isopropanol solution, and make sure that no deposits are left in the wells.

In the case of radioactive spillages, Techne recommend that you use a proprietary cleaning agent. Carefully follow the cleaning agent manufacturer's instructions. The heat/cool block is made of aluminium. Therefore, an agent such as Neutracon (from Decon Laboratories Ltd.), suitable for nonferrous metals should be used but remember other parts of the unit are made of ferrous materials and may be damaged by spillage onto them.

Before using any cleaning or decontamination method except those recommended here, the responsible body should check with Techne that the proposed method will not damage the equipment.

You can clean the case or the screen of the TC-512 with a cloth dipped in water or ethanol (methanol or formaldehyde can also be used). No part of the case or cover should be immersed in the solvents. Do not use aggressive solvents such as acetone, or abrasive cleaners.

Block removal

The blocks can be removed for a more detailed cleaning.

Ensure that the unit is disconnected from the mains for removal of block.

Slide the quick release handles in the direction shown above and lift the assembly out of the unit. Never lift or carry the block by one quick release handle, always use both handles or support the block underneath. When refitting the block, slide the quick release handles in the opposite direction to the above arrows to lock the block assembly into the unit.

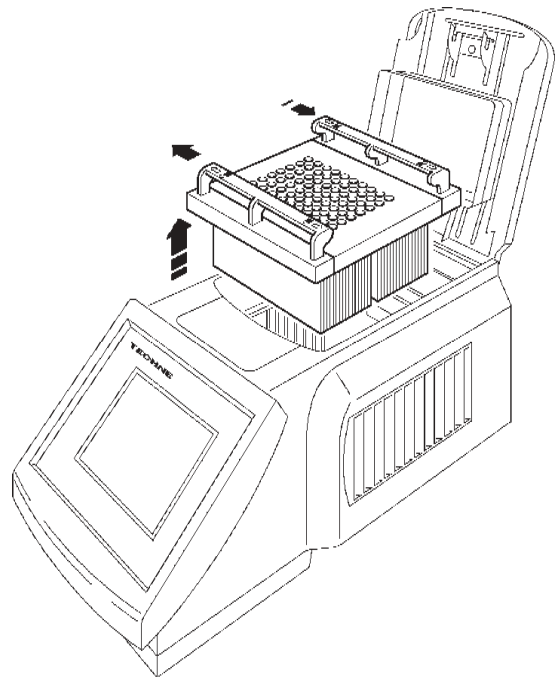

The heated lid

The heated lid is an integral part of the TC-512. It can be switched "On" or "Off", see 'Program Defaults' or 'Editing screen'.

To open the lid lift the back of the handle as shown and use it to lift the lid. To close the lid lower the lid onto the block with the samples in and press the handle shut.

The rubber pad for inside the lid is loose so that it can be replaced easily or used when appropriate. The part number of the loose mat is 6104978.

The rubber mat supplied with the unit is for use with microplates when sealing using a plastic adhesive film. The rubber mat should be placed on top of the sealing film to ensure good thermal contact with the heated lid.

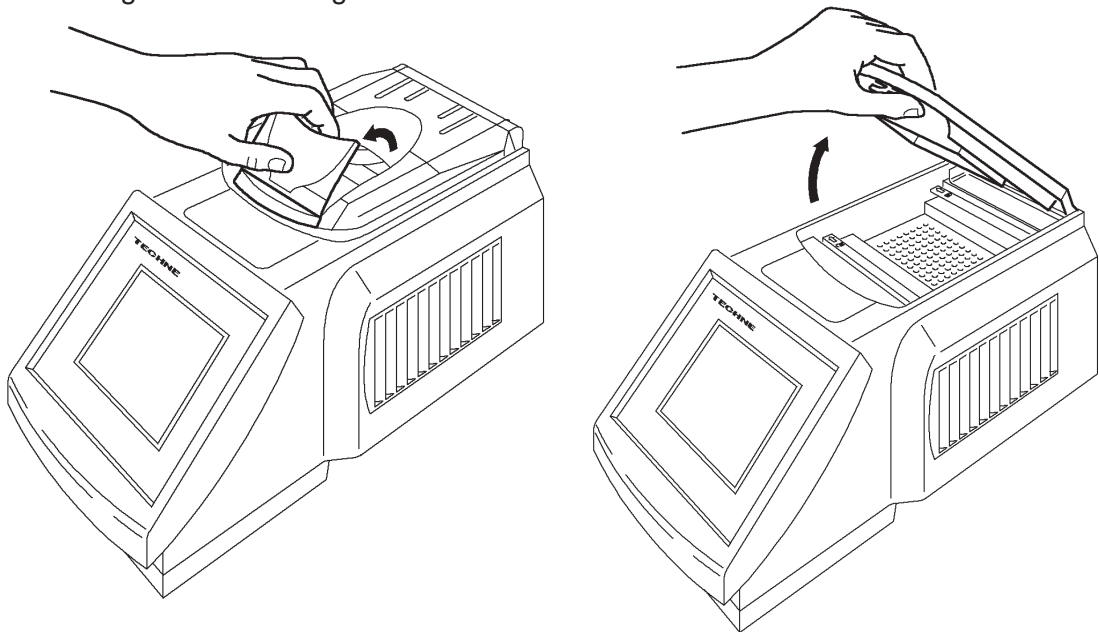

To adjust the pressure on the samples:

The heater plate height should only be adjusted with the lid in the down position, as shown, but not necessarily latched.

Adjust the orange rotating knob anticlockwise to give minimal pressure, shut the lid and latch it. Gently rotate the knob clockwise until you can just feel pressure beginning to be applied. Rotate the knob a further quarter of a turn and this will give the correct pressure. Do not over-tighten the knob as this will cause deformation of the silicone rubber membrane and reduce the effectiveness of the lid. Once the pressure has been set it does not need to be adjusted unless a different block, and hence a different type of sample holder, is used.

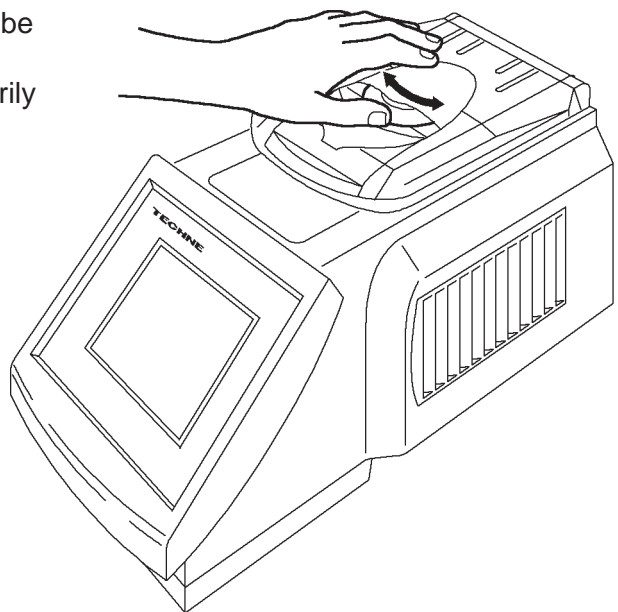

The memory card

The Memory Card is inserted into the slot under the cover at the front of the unit. Lift the cover and push the Memory Card into the slot until the button at the left-hand end of the slot rises. Ensure that the Memory Card is inserted correctly by positioning the card so that the 'front' label is facing you.

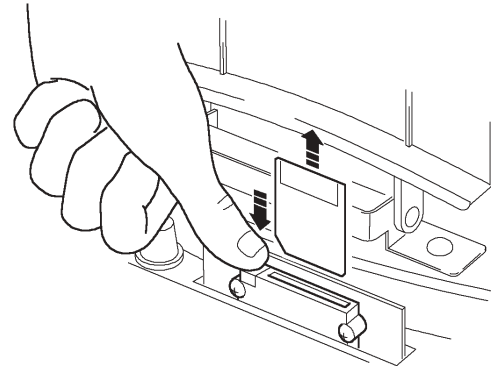

The Memory Card can be used for storing the programs and data logs of program runs. The memory card slot also allows upgrades of the control software. Either via copying software from a new unit and transferring it to an older unit, or by obtaining a copy of the new software from Techne. This is a relatively easy process, see the "System Administration" card, and means that you can keep your unit up to date with the latest software.

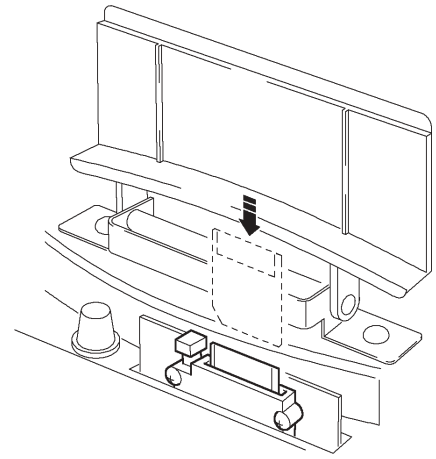

Adjusting the light Intensity of the screen

The light intensity of the screen can be adjusted to suit various environmental conditions. Lift the front cover and you will see a small black knob on the left-hand side of the cavity. Rotating this knob clockwise will make the screen lighter and rotating it anticlockwise will make the screen darker. Adjust the screen to suit your light conditions.

Adjusting Knob

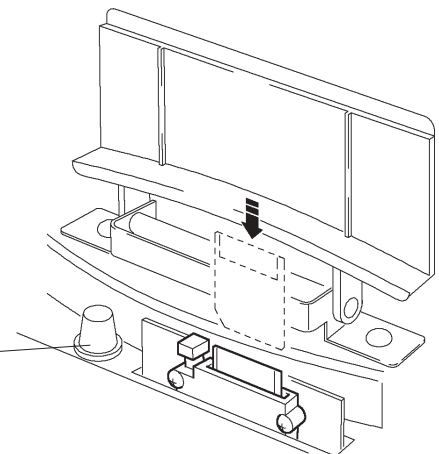

Before switching on

Ensure that the voltage selector switch is set to the appropriate voltage for your supply.

Connections on the back of the unit

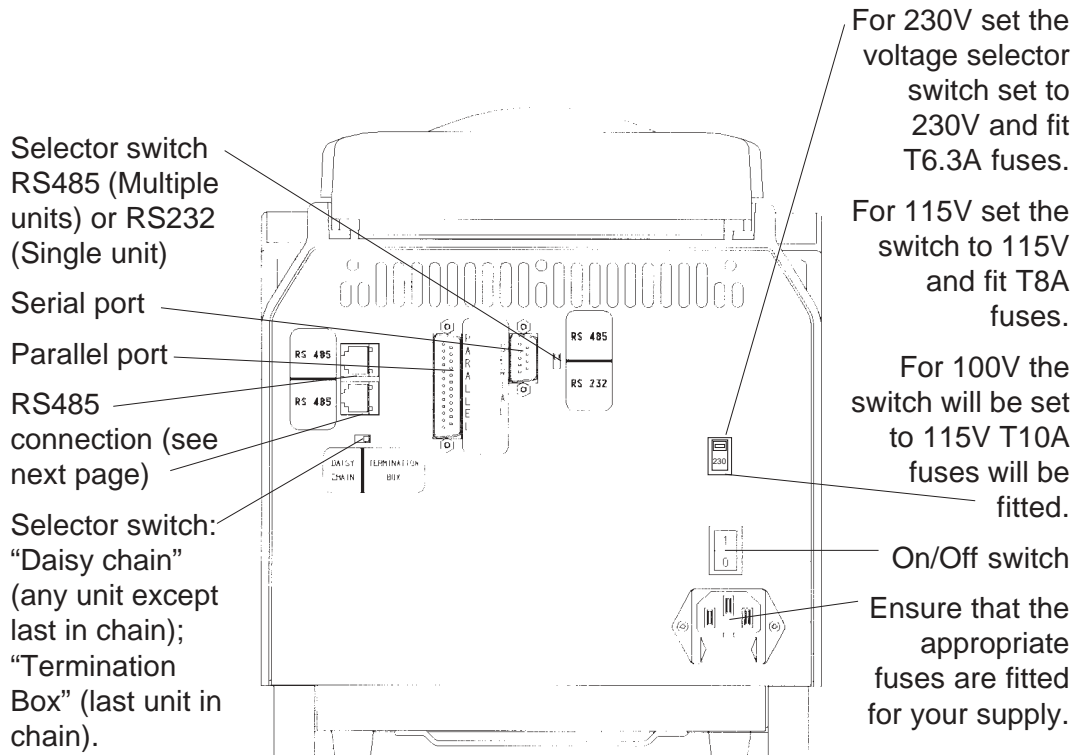

Symbols on the screen

∠ is the symbol for setting the gradient

Connecting one unit to the computer using an RS 232 cable

If you are driving one unit only you will need FGEN232 which includes; a cable, the software on disc and an instruction sheet.

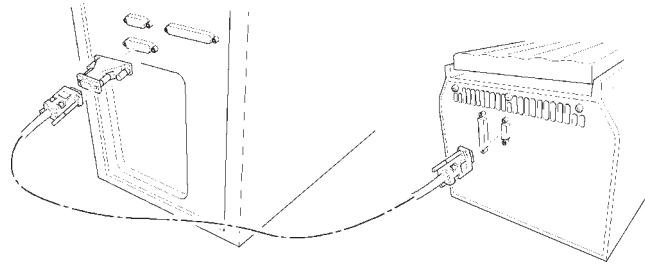

Connecting several units to the computer using the daisy chain cables

If you are driving two or more units then you will need FTG485D an RS485 pack set. A pack set includes: the connection to a computer which also converts to RS485; a 1 metre cables and the software on disc with an instruction sheet. You will also need one of the following for each unit in the 'Daisy Chain':

6103557 Connecting cable.

Notice from the diagram that the cable connections to the Cyclers are alternately bottom to top on the connector.

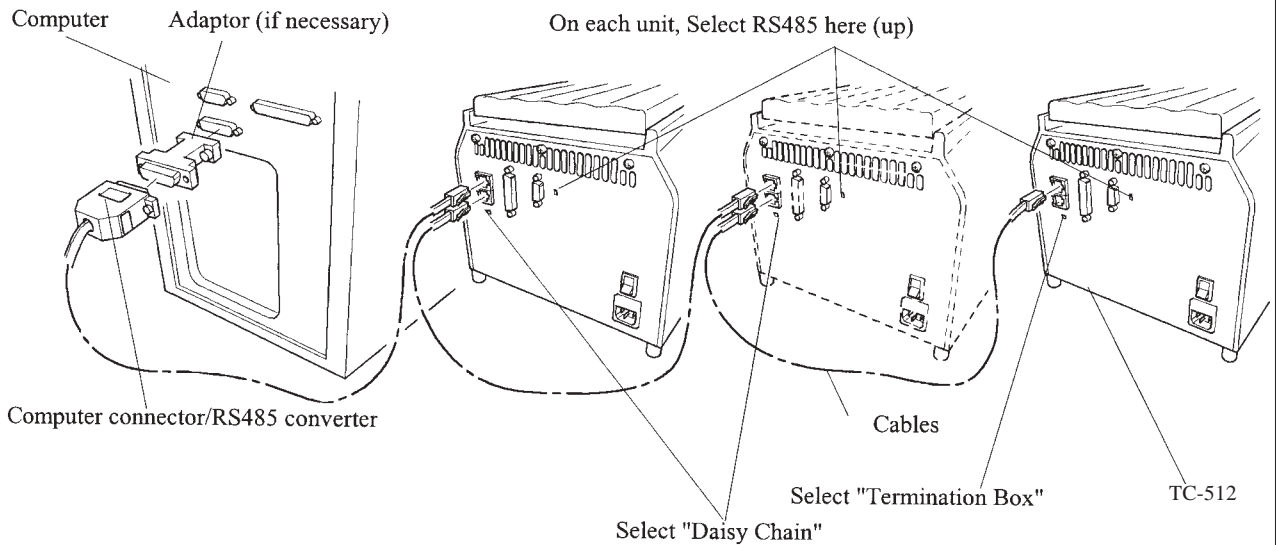

Some frequently asked questions

- Q1 What's the 'pause function' (as far as it concerns the before program operation)?
- A1 Some users prefer to preheat the heated lid before placing the samples into the unit. The pause feature is used to stop the unit after the 4 minute heated lid preheat step. It will also sound an audible alarm indicating that the the machine is ready for the sample tubes or plate to be added. Pressing 'unpause' twice will commence the remaining program.
- Q2 Why do you have to press some keys twice to make the unit do what you want it to do.?
- A2 With many of the program features there is a fail-safe function which asks if you are sure you want to perform a particular action. You then have to press a key a second time.
- Q3 What is the appropriate pressure of the heated lid? If we do it the way it is described in the manual the tubes are stuck on the membrane.
- A3 If the tubes stick to the lid then this could be because there is some grease or dirt on the rubber pad. We recommend that the user occasionally dusts the rubber pad with talcum powder to avoid sticking. It is important not to overtighten the lid *a light contact is sufficient*.
- Q4 What is "Hot start"?
- A4 Hot Start is used to make the machine pause after the initial denaturation at a specific temperature, typically around 70°C. The reason is to allow the addition of TAQ enzyme after the initial 5min denaturation, this prolongs the half-life and activity of the enzyme.
- Q5 What is the incremental function? See pages 30 and 31.
- A5 Incremental timing and temperature are used to increase either the time or temperature incrementally over the 30 cycles.
 Incrementation of time is used with 'Long PCR' which is when large template fragments are to be amplified (27KB lambda, 40KB genomic).
 Decremental temperature is used for protocols such as 'Touchdown PCR' where one starts at a high anneal temperature and gradually decrease the temperature over the 30 cycles, this ensures a highly specific product is amplified.
- Q6 The way you enter a new programm is not quite understandable.
- A6 The logic of this manual is as follows:
- a Open programs
 - 1 New programs
 - 2 Templates
 - 3 Existing programs
 - b Edit programs (including adding segments, loops, etc, to a new program)
 - c Run programs
- Once you are doing what the heading says you remain in that function until you get to another heading.
- Q7 It is not always clear the order that you add parts to the program.
- A7 The software will always add a line if you have missed it out. For example if you add a 'segment' and you have not added the 'cycles' the software will add a line 'Number of Cycles 1' above the segment. You can then edit this line if you require more than one cycle.
 If you require further assistance please telephone Techne with the unit in front of you and we can go through the programming function.

Power up screens

Techne TC-512	
Serial number	GPxxxx/xx
Software version	v.vv
Hardware version	h.hh
Block ID	Grad 96 x 0.2ml
Last system test	dd/mm/yyyy
Copyright protected 2000	
Performing self tests	
1	2 3

The screen is a touch sensitive LCD graphics screen. Operator input temperatures are temperatures which you require the sample to achieve. Displayed temperatures are either the temperatures measured by the block probe, the calculated sample temperature or both.

The screen shown is displayed when the unit is powered on and will remain displayed while the unit performs its self tests. After the self-tests this screen is displayed unless the unit is powered up by auto-restart see a later section.

An example of a 'field' with full corners which are dialogue windows and have no effect when touched.

Techne TC-512

System User

An example of a 'field' with cutaway corners which are touch sensitive and give the user some sort of action when touched.

Techne TC-512	
Serial number	GPxxxx/xx
Software version	v.vv
Hardware version	h.hh
Block ID	Grad 96 x 0.2ml
Last system test	dd/mm/yyyy
Comms address	01
Copyright protected 2000	
System User	System Admin

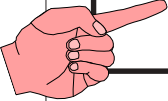

System User button

This selects normal user functions as shown on the next screen.

System Admin button

This selects administration functions and is dealt with in the system administration section.

System user main menu

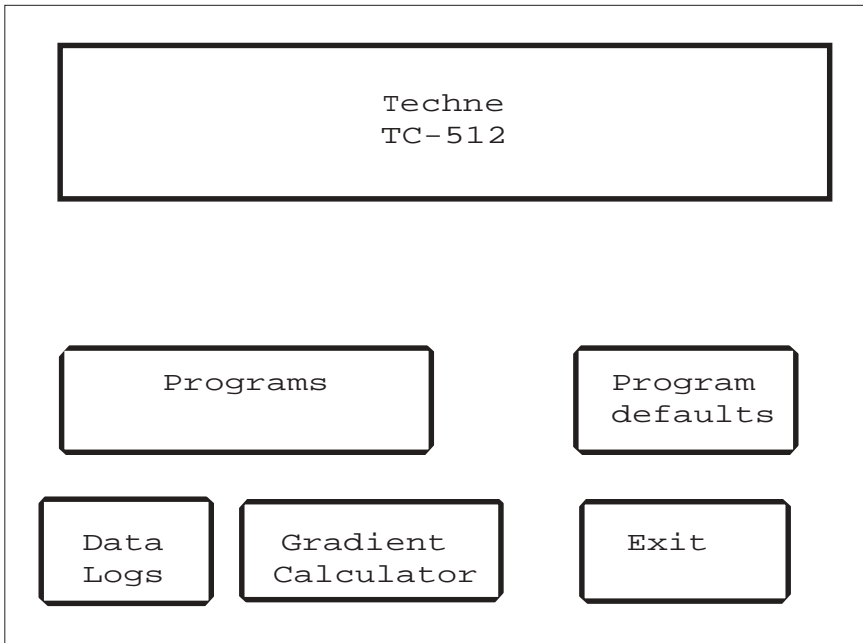

Programs

By touching this button you can access all the programs stored either internally or in the memory module, see page 20.

Program defaults

By touching this button you can set up the program defaults for a number of programs. See below.

Data Logs

By touching this button you can access the data logs stored in the plug in memory module. See a later section of this manual, pages 34 and 35.

Gradient Calculator

See page 28.

Exit

By touching this button you can return to the previous screen.

Program defaults

Pause before program Off

One touch gives:

Pause before program On

A second touch will return the field to the first example.

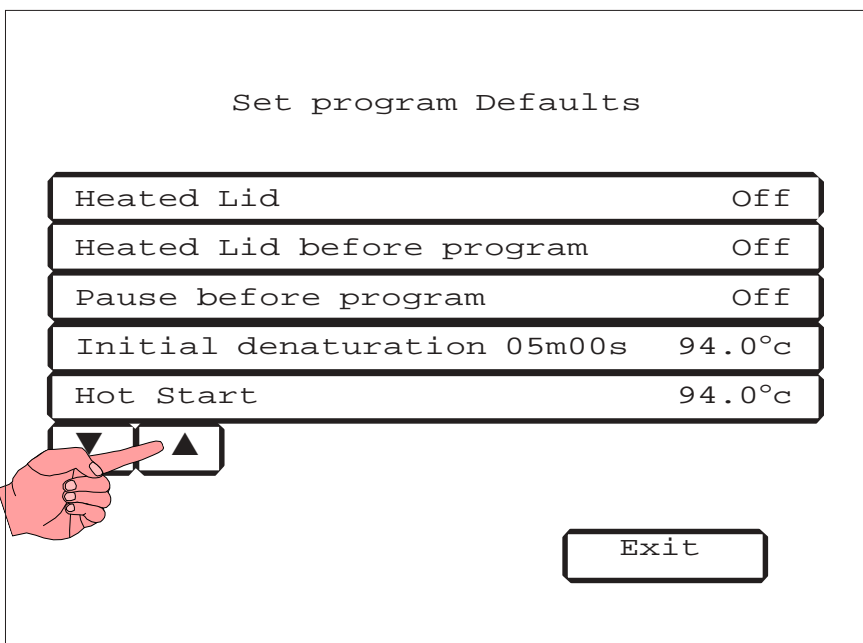

When you touch this button you can set up default settings for the programs you are about to put into the unit.

First is an example where if you touch the button for a field where there is either ON or OFF then the field will toggle between the two.

If you touch a button where there is a numerical input it will transfer you to an input screen. An example is given on the following pages.

If you touch the '▼' down arrow button the screen will toggle down to a maximum of four more fields as shown on the next screen. You can then toggle back using the '▲' up arrow button.

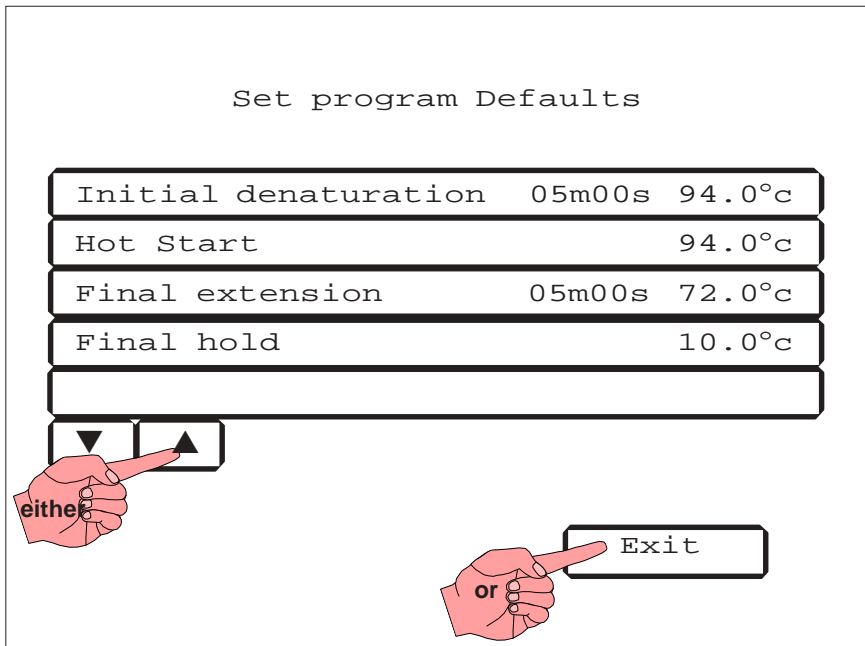

Once you have set the defaults to those required, you return to the "System User Main Menu" screen by touching the Exit button.

Numerical Input Screen

An example only is shown. All the screens where a numerical input is required are similar. The 'h', 'm' and 's' will only appear where the field requires hours, minutes or seconds.

The '← →' arrow buttons only operate where you need to change fields.

The '**Disable**' button puts 'xxxx' in the fields. The button itself will change to 'Enable'. If the segment was previously "Disabled" the reverse will happen and you will be able to put numerical values in the field.

The '**Cancel**' button takes you back to the previous screen without any changes.

The '**BS**' button is a back space, if you are at the beginning of a field it will delete the whole field: if you are in the middle of a field it will delete the previous digit.

Type in the program information; with the units of time where appropriate. The order of the time is not important, for example if you type in 5s2m the unit will convert it to 02m05s.

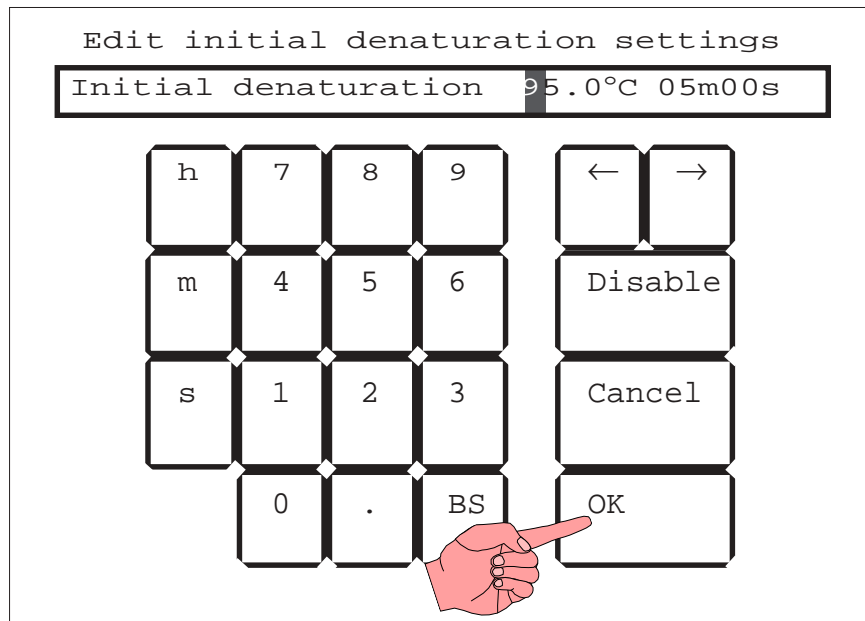

Touch '**OK**' when you have entered the your program information.

You will return to the "Program" screen.

Programs

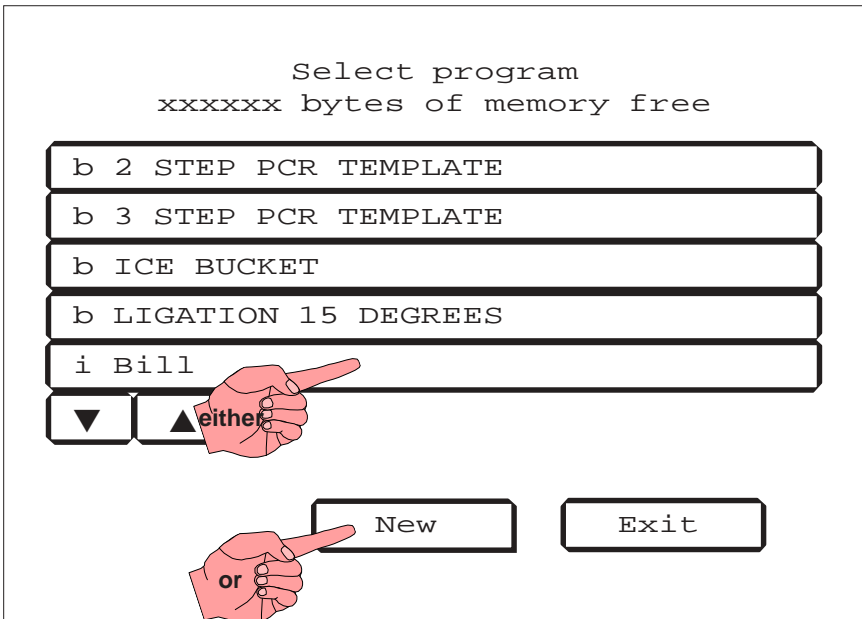

Touch the 'Programs' button in "System User Main Menu" and you will go into the "Select Program" screen.

How to use "New" programs is explained below.

An "Existing" program with: a "b" prefix is a 'basic' program or "Template" (how to use these is explained on page 21); an "i" prefix means the program is stored 'internally'; an "r" prefix means the

program is stored on the memory card or 'remotely' (how to edit and use existing programs are explained on page 23).

Use the, 's' or 't', down arrow or up arrow key to toggle through the programs. Select any one by touching the appropriate field.

If you touch 'Exit' you will return to the System User Main Menu.

New program screen

If you choose 'New' then you will go into an input screen to give the program a name. Once you have entered the name, you will go into the 'Editing' screen.

Touch the 't' down arrow button to toggle more parts of the program. You can then toggle back using the 's' up arrow button.

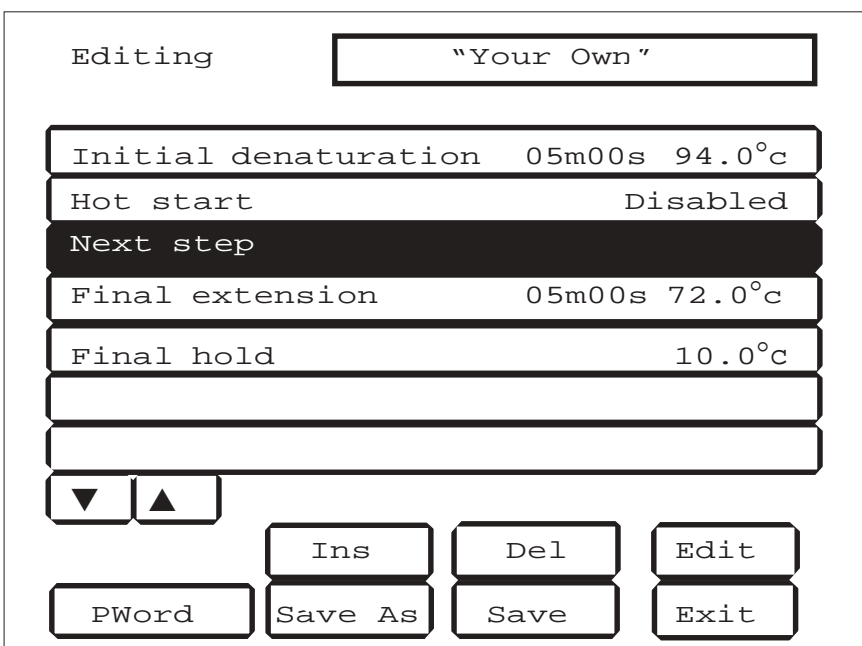

'Del(ete)' will only be effective for saved programs.

'Ins(ert)' will only be effective if there is no "Next step" field.

'Save As' will give the program a different name. 'Save' will save the program.

'Edit' will put you into the "Edit program function" screen.

'Exit' will return you to the "Program" screen.

'PWord' will allow you to give the program a password so that other people cannot edit your program, see page 24.

Template program screens

Program	2 STEP PCR TEMPLATE		
Last Modified	01/00/2000 00:00:00		
Heated Lid	105.0°C		
Heated Lid before program	On		
Pause before program	Off		
Initial denaturation	05m00s	94.0°C	
Hot Start	Disabled		
Number Cycles	30		
▼	▲		
Run	Copy	Delete	Edit
	Print	Exit	

Program	2 STEP PCR TEMPLATE		
Initial denaturation	05m00s	94.0°C	
Hot Start	Disabled		
Number Cycles	30		
Seg	MAX°C/m	00m30s	92.0°C
Seg	MAX°C/m	01m00s	68.0°C
Final extension	05m00s	72.0°C	
Final Hold	10.0°C		
▼	▲		
Run	Copy	Delete	Edit
	Print	Exit	

Any template program can be copied and given a new name.

From "Select Program" screen if you touch "2 step PCR template" you will come to this screen.

Touch '**Copy**' and you will go into the title screen. Type in your name for the program and touch '**Enter**'.

If you try to '**Edit**' any of these programs you will find that you can only "Save as" when you finish. The 'Save' key will not be on the screen.

If you touch '**Delete**' you will be asked if you are sure you want to delete the program. Select 'Yes' or 'No'.

Before you touch '**Print**' make sure that you have a printer connected to the TC-512. If you touch 'Print', and you have a printer connected, it will print out the program.

If you touch '**Run**' the unit will start to run the selected program. See a later section on page 32.

The other keys work as for any other screen.

Touch the '▼' down arrow button to toggle more parts of the program.

You can then toggle back using the '▲' up arrow button.

Program 3 STEP PCR TEMPLATE

Hot Start	Disabled
Number Cycles	30
Seg MAX°c/m 00m30s 92.0°c	
Seg MAX°c/m 00m30s 55.0°c	
Seg MAX°c/m 00m30s 72.0°c	
Final extension	05m00s 72.0°c
Final Hold	10.0°c

▲ ▼

Copy
Delete
Edit

Run
Print
Exit

The 3 step PCR template has the seg(ments) shown here. Other settings are as for the 2 step template.

Program ICE BUCKET

Heated Lid	Disabled
Heated Lid before program	Off
Pause before program	Off
Initial denaturation	Disabled
Hot Start	Disabled
Final extension	Disabled
Final hold	4.0°c

▲ ▼

The "Ice Bucket" template has all fields set to 'off' or 'disabled' except the final hold temperature which is set to 4.0°C.

Program LIGATION 15 DEGREES

Heated Lid	Disabled
Heated Lid before program	Off
Pause before program	Off
Initial denaturation	Disabled
Hot Start	Disabled
Final extension	Disabled
Final hold	15.0°c

▲ ▼

The "Ligation 15 degrees" template has all fields set to 'off' or 'disabled' except the final hold temperature which is set to 15.0°C.

Existing program screen

Program	Bill	
Last Modified 19/08/2000 14:16:43		
Heated Lid	Disabled	
Heated Lid before program	Off	
Pause before program	Off	
Initial denaturation	Disabled	
Hot Start	05m00s	94.0°C
Final extension	Disabled	
<div style="display: flex; justify-content: space-between; align-items: center;"> <div style="display: flex; gap: 5px;"> ▲ ▼ </div> <div style="display: flex; gap: 10px;"> Copy Delete Edit </div> </div>		
<div style="display: flex; justify-content: space-between; align-items: center;"> Run Print Exit </div>		

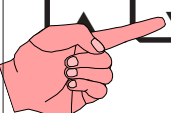

If you select an existing program from the “Programs” screen you will get a screen similar to this one.

Touch the ‘▼’ down arrow button to toggle more parts of the program. You can then toggle back using the ‘▲’ up arrow button.

If you touch ‘Delete’ you will be asked if you are sure you want to delete the program. Select ‘Yes’ or ‘No’.

Before you touch ‘Print’ make sure that you have a printer connected to the TC-512. If you touch ‘Print’, and you have a printer connected, it will print out the program.

If you touch ‘Run’ the unit will start to run the selected program. See a later section on page 32.

In order to edit the program you must touch the ‘Edit’ button to get into the “Editing” screen. For editing see the following pages.

‘Exit’ will return you to the “System User Main Menu”.

Program	Bill	
Last Modified 19/08/2000 14:16:43		
Heated Lid	Disabled	
Heated Lid before program	Off	
Pause before program	Off	
Initial denaturation	Disabled	
Hot Start	05m00s	94.0°C
Final extension	Disabled	
<div style="display: flex; justify-content: space-between; align-items: center;"> <div style="display: flex; gap: 5px;"> ▲ ▼ </div> <div style="display: flex; gap: 10px;"> Copy Delete Edit </div> </div>		
<div style="display: flex; justify-content: space-between; align-items: center;"> Run Print Exit </div>		



Editing programs

Program	Bill		
Last Modified 19/08/2000 14:16:43			
Heated Lid	Disabled		
Heated Lid before program	Off		
Pause before program	Off		
Initial denaturation	Disabled		
Hot Start	05m00s	94.0°C	
Number Cycles	3		
▼	▲		
Run	Copy	Delete	Edit
	Pr		Exit



From the "Program" screen touching 'Edit' puts you into a very similar screen. The top field will have gone and the next field will have appeared at the bottom of the set of seven fields, as shown in this picture.

Password protection

Editing	Bill		
Initial denaturation Disabled			
Hot Start 05m00s 72.0°C			
Number Cycles 3			
Seg MAX°C/m 00m30s 92.0°C 410°C			
Seg MAX°C/m 00m30s 92.0°C			
Next step			
Final extension Disabled			
▼	▲		
PWord	Ins	Del	Edit
	Save As	Save	Exit

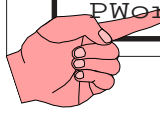

If you do not want other people editing the program it may be password protected using 'PWord'. You will need to enter it twice to confirm the password.

Next time you go into "Editing", the 'PWord' key will have changed to Touch any field you need to edit and it will become highlighted.

Change PWord

Editing Bill

Heated Lid	Disabled
Heated Lid before program	Off
Pause before program	Off
Initial denaturation	Disabled
Hot Start	05m00s 94.0°C
Number Cycles	3
Seg MAX°C/m	00m30s 92.0°C Δ10°C

▼ ▲

Ins	Del	Edit	
PWord	Save As	Save	Exit

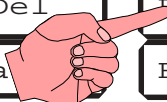

Switch a function on or off



If the field has “On” or “Off”, the field will toggle between “Off” and “On” when you touch the ‘Edit’ button with the field highlighted.

Editing Bill

Initial denaturation	Disabled
Hot Start	05m00s 72.0°C
Number Cycles	3
Seg MAX°C/m	00m30s 55.0°C Δ10°C
Seg MAX°C/m	00m30s 92.0°C
Next step	
Final extension	Disabled

▼ ▲

Ins	Del	Edit	
PWord	Save As	Save	Exit

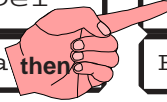
Editing Numerical Values

If the field has a numerical value or says “Disabled”, you will get a “Numerical Input” screen when you touch the ‘Edit’ button with the field highlighted.

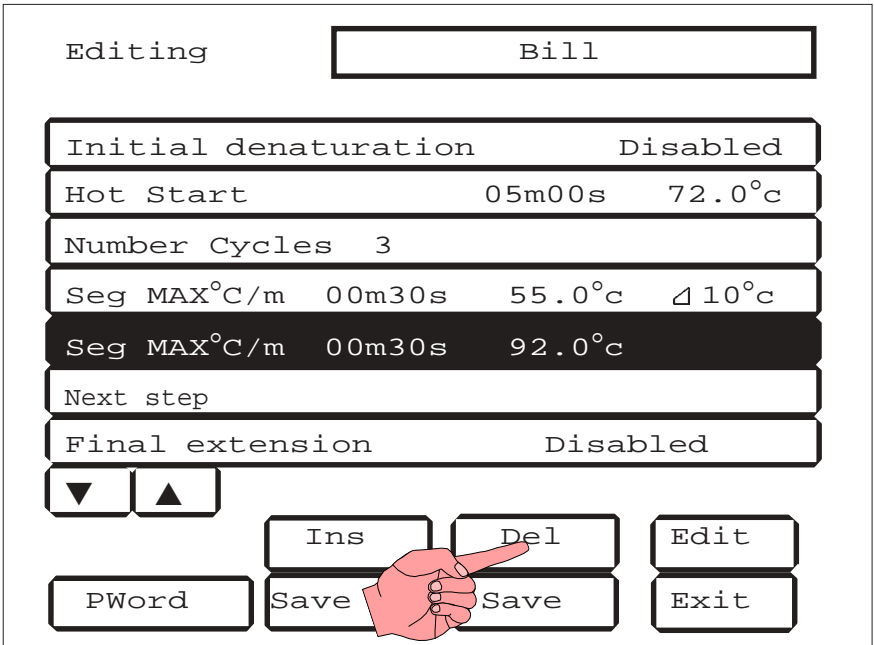

Deleting a Segment

'Del' will delete any segment which is highlighted, but you will be asked to confirm the deletion.

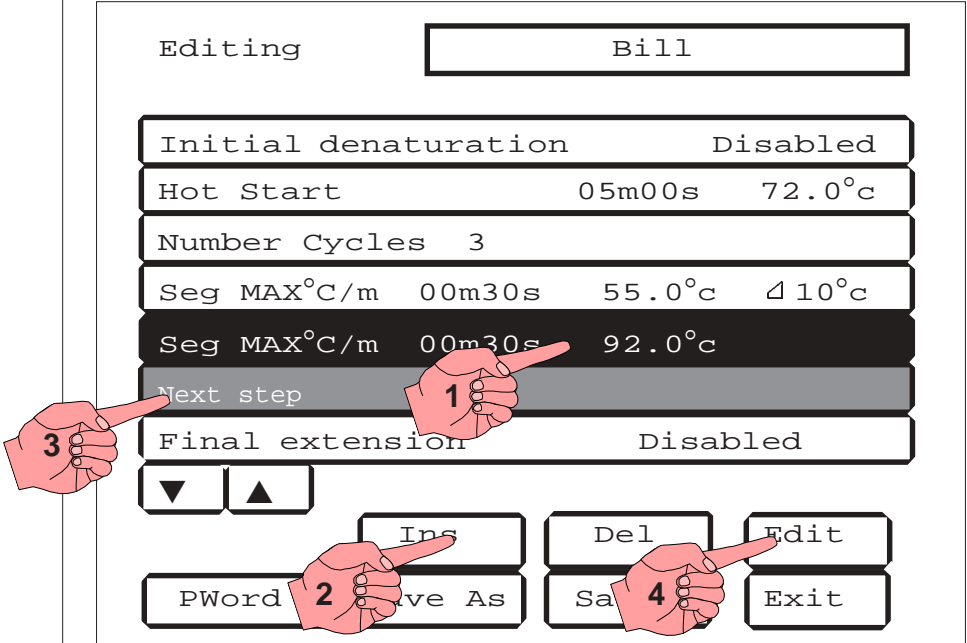

Inserting Extra Functions

- 1 Highlight the field after which you wish to add program information, for example the second "Seg(ment)" in the illustration.
- 2 Touch 'Ins(ert)'. A "Next Step" will be added after the highlighted field. (Or you can use the "Next step" that the program inserts automatically.)
- 3 Touch the 'Next Step' field and highlight it.
- 4 Touch 'Edit'. You will now be in the "Edit Program Function" screen.

Edit program function

Next Step

Segment	h	7	8	9	←	→
Number Cycles	m	4	5	6	Continue	
Inc Dec	s	1	2	3	Cancel	
Pause		0	.	BS	OK	

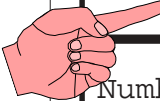

Segment

Touch 'Segment' to insert a segment.

Type in the Temperature as appropriate.

Use the "Right Arrow" key '→' to move to the Gradient field.

Type in the Gradient as appropriate. See page 28.

Use the "Right Arrow" key '→' to move to the Time field.

Type in the Hold Time as appropriate.

Use the "Right Arrow" key '→' to move to the Ramp field.

Type in the Ramp Rate as appropriate. The Ramp rate you put in here will be the rate from the temperature at the beginning of the "Segment" to the temperature of the mid-point of the "Gradient". Rates to the highest and lowest temperatures will be adjusted appropriately.

Edit program function

Seg █ 75.0°C ▽ 0°C 00m30s MAX°C/m

Segment	h	7	8	9	←	→
Number Cycles	m	4	5	6	Continue	
Inc Dec	s	1	2	3	Cancel	
Pause		0	.	BS	OK	



The gradient

The Set Temperature is the temperature that you require of the MIDDLE ROWS of samples in the block. The GRADIENT is the variation of the two extremes of the samples in the block; the left-hand side being the coolest and the right-hand side being the hottest.

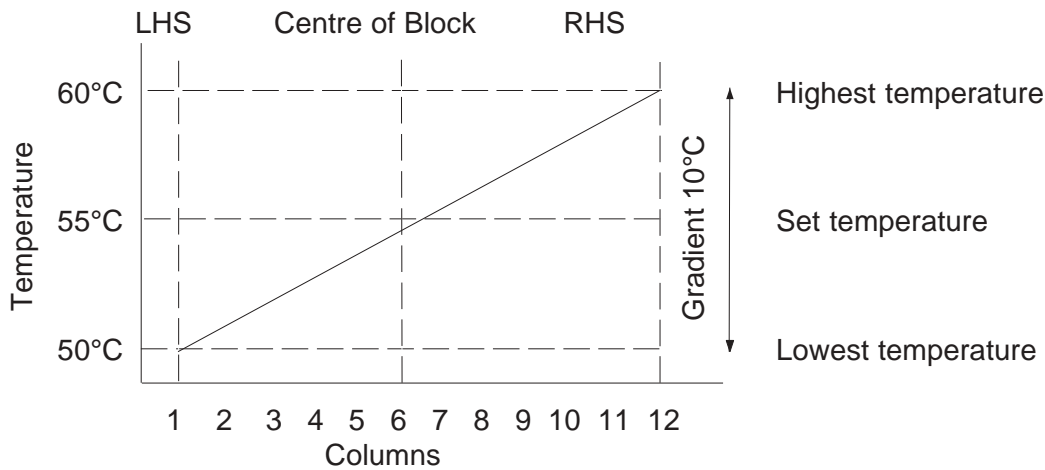

The Maximum gradient is 30°C; the lowest cold temperature is 20°C and the hottest temperature is 70°C. However, you must remember that the greater the gradient the poorer the uniformity.

The illustration shows a

Set Temperature of 55°C with a Gradient of 10°C on a 0.5ml x 60 block.

Other examples: Set temperature of 55°C with a gradient of 20°C will give a low of 45°C and a high of 65°C; a set temperature of 50°C with a gradient of 16°C will give a low of 42°C and a high of 58°C.

Gradient Calculator

Temperature 55°C
Gradient 10°C

50.6	52.0	53.7	55.2	57.2	58.8				
51.2	52.9	54.6	56.2	58.0	59.2				

Gradient

Temperature

Print

Exit

Gradient Calculator

While the gradient is substantially linear there are small variations. We have, therefore, included a gradient calculator to give you a more accurate picture of the gradient.

Touch the 'Gradient Calculator' button in "System User Main Menu", see page 18, and you will go into the "Gradient Calculator" screen.

An example is shown here but please note that this is an idealised picture for this manual and you must use the unit screen to get the accurate picture for your block.

Edit program function

Next Step

Segment	h	7	8	9	←	→
Number Cycles	m	4	5	6	Continue	
Inc Dec	s	1	2	3	Cancel	
Pause		0	.	BS	OK	

If you want to add other information, touch **'Continue'** then the appropriate key

Cycles and/or Pause

You can also insert **'Number of Cycles'**, and/or a **'Pause'** as appropriate and adjust the values to suit.

Edit program function

First	75.0°C	Δ 0°C	00m30s	MAX°C/m
Last	75.0°C	Δ 0°C	00m30s	MAX°C/m

Segment	h	7	8	9	←	→
Number Cycles	m	4	5	6	Disable	
Inc Dec	s	1	2	3	Cancel	
Pause		0	.	BS	OK	

Inc/Dec time or temperature

You can insert an incremental value for Time or Temperature and these are illustrated on the next page. Touch **'Inc/Dec'**.

To Program increment or decrement temperature or time.

Under normal circumstances, the Hold Temperature of all segments is constant. However, it is possible to automatically increment or decrement the temperature of a specified segment of a programme.

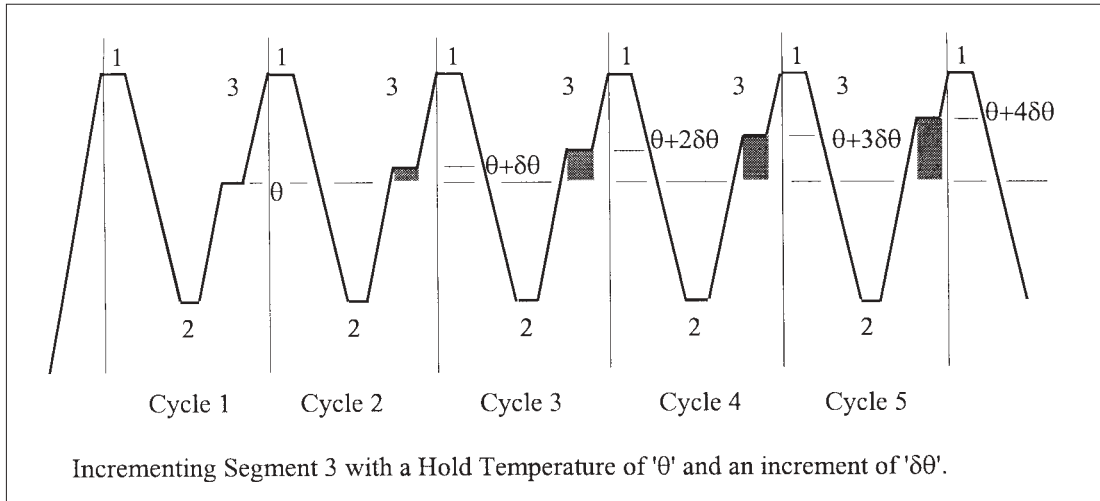

The Hold Temperature of the incremented/decremented segment is the defined Hold Temperature plus the summation of the increments/decrements. The first cycle is never incremented/decremented, only subsequent Cycles. If you select a decrement, the Hold Temperature is prevented from falling below 4°C. If you select an increment, the Hold Temperature is prevented from rising above 99°C.

Similarly, under normal circumstances, the Hold Time of all segments is constant. However, it is possible to automatically increment or decrement the duration of a specified segment of a programme.

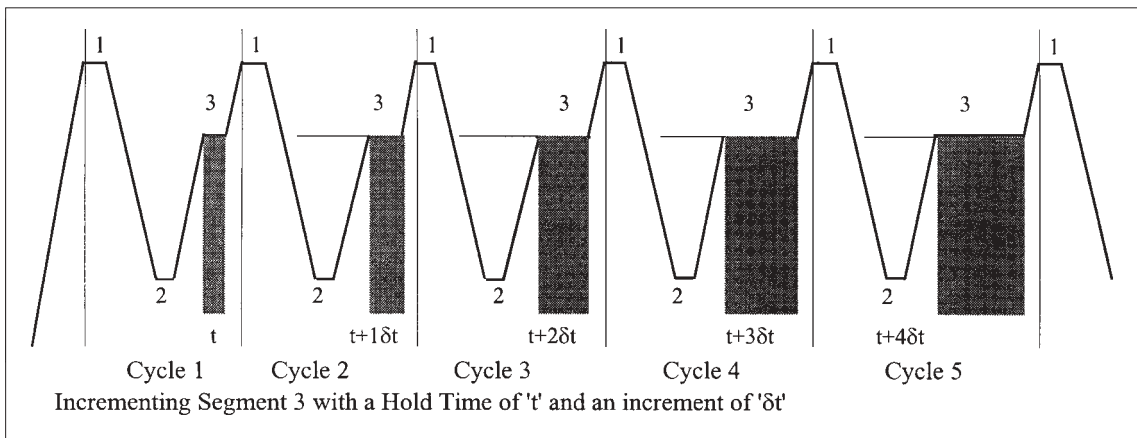

The Hold Time of the incremented/decremented segment is the defined Hold Time plus the summation of the increments/decrements. The first cycle is never incremented/decremented, only subsequent Cycles. If you select a decrement, the Hold Time is prevented from falling below one second.

Edit program function

Next Step

Segment	h	7	8	9	←	→
Number Cycles	m	4	5	6	Disable	
Inc Dec	s	1	2	3	Cancel	
Pause		0	.	BS	OK	

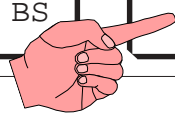

Completion

Touch 'OK' when you have the values you need in each of the fields. You will return to the "Editing" screen.

'Save' before 'Run'

Editing "Your own"

Heated Lid	Disabled
Heated Lid before program	Off
Pause before program	Off
Initial denaturation	Disabled
Hot Start	05m00s 72.0°C
Number Cycles	3
Seg MAX°C/m	00m35s 75.0°C Δ 0°C

▼

▲

Ins

Del

Edit

PWord

Save As

Save

Exit



Once you are satisfied that the information is correct you **must** "Save" the program. Touch 'Save'.

Alternatively you can give the program a different name by touching 'Save As' and following the on screen instructions.

No Change

Use 'Exit' to return to the "Program" screen without editing any information. If you have made changes it will ask you if you want to save them.

Running a program

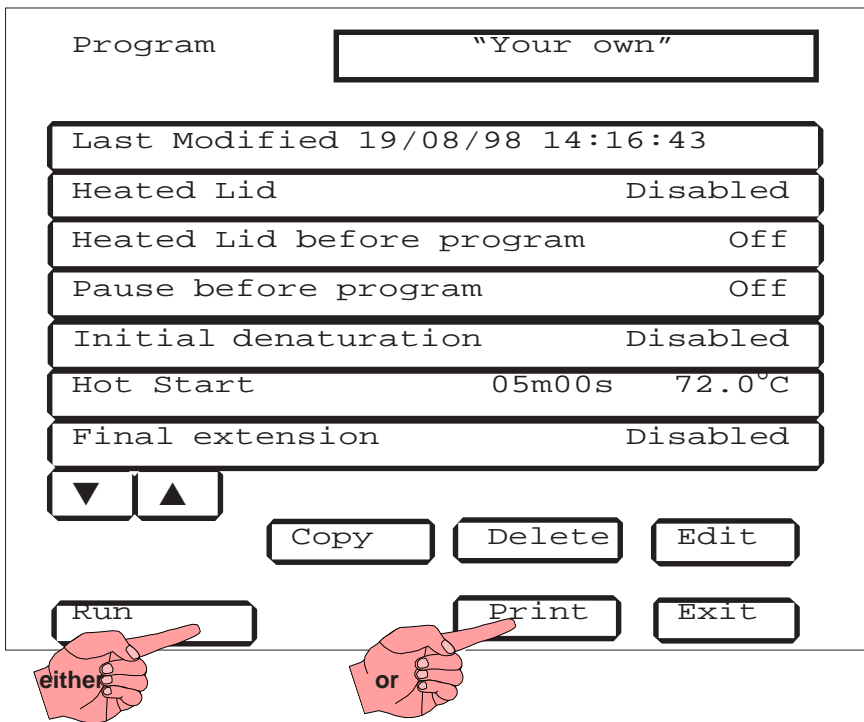

From the “Select program” screen you will go into the “Program” screen for the program selected.

Alternatively, from the “Editing” screen you will go back into the “Program” screen when you ‘Save’ or ‘Save as’.

From the “Program” screen when you touch ‘Run’ you will be asked if you wish to data log the run.

If you answer ‘Yes’ then you will be asked to give the data log a name. For printing out the data log and so on see a later section on page 34.

Typical Program Printout

From the “Program” screen you can print the program by touching the ‘Print’ key. A typical print-out is shown below.

TC-512 program		02/12/98 08:29:44	
System Version	:0.49	1.00	
TC-512 Serial Number	: 88192/01		
Program	: DEPT PROGRAM		
Date last edited	: 12/10/1998 22:48:11		
Auto Restart	: Enabled		
Password Protection	: Disabled		
Heated Lid	: Enabled		
Initial Denaturation	: Disabled		
Hot Start	: Disabled		
01 Cycles			
Segment	Set Point°C	RampRate°C	HoldTime
	4.0	Max	00:10:00
03 Cycles			
Segment	Set Point°C	RampRate°C	HoldTime
	95.0	Max	00:00:30
	55.0	Max	00:00:30
	72.0	Max	00:01:00

While running programs

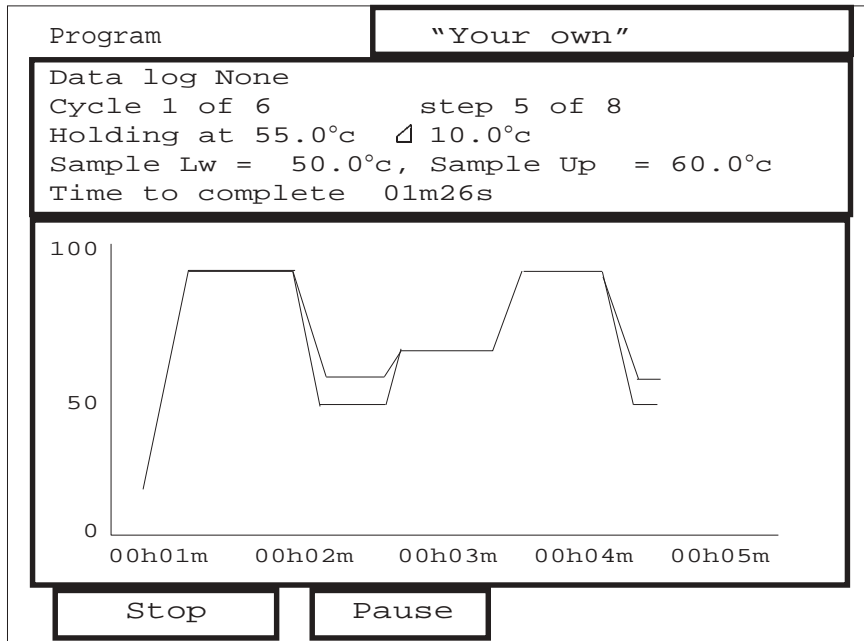

As the program progresses you will eventually get a screen similar to this diagram. The trace is plotted from the right-hand side and so initially you will have a blank graph with two axis lines. The trace will consist of one or two lines, the block

temperature, the sample temperature or both, this depends on the selection you made in "Program Defaults".

If you wish to pause the program touch the **'Pause'** button. Press **'Unpause'** and the program will continue.

If you wish to stop the program, you have to press **'Stop'** twice. This is to prevent accidental interruption of the program. The fields at the bottom of the screen will change to 'Run' and 'Exit'. Touching **'Run'** will start the program **from the beginning again**. Touching **'Exit'** will take you back to the program screen.

Data logs

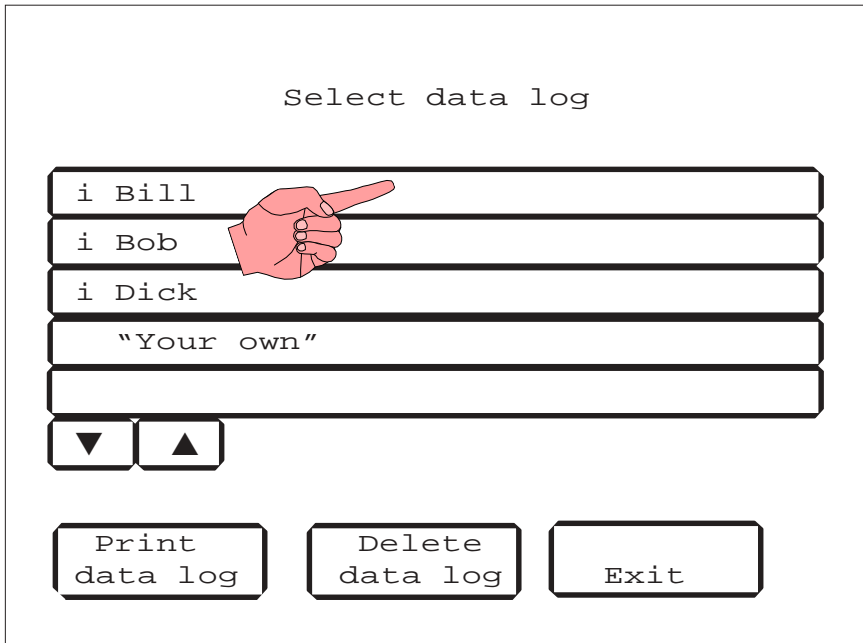

Once a program has run and the data has been logged, it can be printed on a Epsom dot-matrix fan-form LX300+ printer. Or it can be deleted. Both actions are performed from the "System User Main Menu". Touch '**Data logs**' and you will get the screen shown here.

Select either '**Print data log**' or '**Delete data log**'. If you select print ensure that you first have a printer connected.

'**Exit**' will return you to the Main Menu.

Printing data logs

As the TC-512 runs, profile information is stored on the Memory Card. This information defines the times and temperatures at various points during the run. A range of events creates data which is used to create a profile of the run.

If you require a printed output give the data log a name when requested, the data will then be stored under that name while the program is running. Once the program is complete, from the "System User" screen choose '**Data Logs**'. Select the Data Log that you want to print by highlighting it. Make sure that the printer is plugged in and set on line *before* pressing the print key. Note that profiles cannot be printed out during calibration.

The events which are used to generate profile information are:

Start	A start of program event is generated on first pressing the run key.
Stop	A subsequent press of the stop key stops a run prematurely. This event generates a printer form feed.
Start of program	Whenever a new program starts. This event generates a Start of cycle event.
Start of cycle	Whenever the current program starts a new cycle. This event generates a Start of Segment event.
Start of segment	Whenever a new segment starts.
Start of Hold Time	Whenever the current segment reaches the Hold Time window.
End of program	Whenever the run ends due to the program finishing. This event generates a printer form feed.
Pause on	Whenever the pause key is first pressed to pause a running program.
Pause off	Whenever the unpaue key is subsequently pressed to end a pause period.

A printed profile is 80 columns wide and uses only standard characters in the ASCII range 1 to 127: thus all common dot matrix, pin fed, continuous stationery printers can be used.

An example of a typical printed profile is shown here:

Note the following:

- The second line shows the block type detected and the software version number.
- At the start of each cycle, the cycle number is shown.
- The start time is the time according to the real time clock in the unit.
- The Rate is prefixed with either a '+' or '-' to indicate a heating (+) or cooling (-) segment.

Typical Data Log Printout

TC-512 program		30/11/98		14:27:25			
		System Configuration.					
		System Version : 0.49 1.00					
		Unit Serial No. : 88192/01					
		Last System test : 19/11/1998 09:34:24					
Program		: DEPT PROGRAM					
Date last edited		: 12/10/1998 22:46:11					
Data Log File		: NORMAN					
Event	Date & Time	Func	Cycle	Step	Temp	Set Point	Ramp Rate
Program	30/11/1998 14:27:26						
Ramping	30/11/1998 14:27:26	01	01	01	4.0°C	4.0°C	MAX °C/m
Holding	30/11/1998 14:27:51	01	01	01	6.3°C	4.0°C	
Ramping	30/11/1998 14:37:52	02	01	01	4.0°C	95.0°C	MAX °C/m
Holding	30/11/1998 14:38:29	02	01	01	88.1°C	95.0°C	
Ramping	30/11/1998 14:38:59	02	01	02	95.0°C	55.0°C	MAX °C/m
Holding	30/11/1998 14:39:26	02	01	02	59.2°C	55.0°C	
Ramping	30/11/1998 14:39:56	02	01	03	55.0°C	72.0°C	MAX °C/m
Holding	30/11/1998 14:40:05	02	01	03	65.5°C	72.0°C	
Ramping	30/11/1998 14:41:05	02	02	01	72.0°C	95.0°C	MAX °C/m
Holding	30/11/1998 14:41:16	02	02	01	88.5°C	95.0°C	
		Signed:					

Typical Graph from a Data Log

Data Log	: NORMAN
Program Name	: DEPT PROGRAM
Time Started	: 30/11/1998 14:27:26

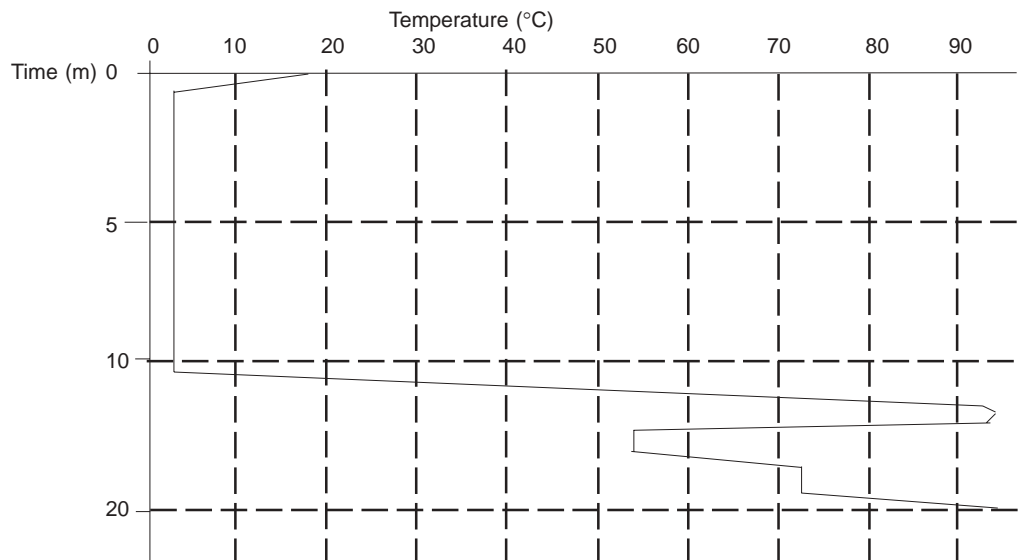

Using Gensoft

The "Gensoft" software package is available to enable you to connect the TC-512 to a computer via a 'Comms' port. "Gensoft" offers:

- A Daisy chaining a number of units together to a maximum of 32 units
- B Creation of thermal cycling protocols through as easy to use Microsoft Windows user interface and transmitting them to one or more units.
- C Selection of units to start and stop a program
- D Diagrammatic status of all units connected, including information on the current position in the protocol of each individual unit and the time remaining.
- F Print out of the protocol in a diagrammatic format together with associated notes page.

If you are driving one unit only you will need:

FGEN232 An RS232 cable set which includes; a cable, the software on disc and an instruction sheet.

If you are driving two or more units then you will need:

FTGEN485 A Computer Connection set.

This set includes: the connection to a computer; the necessary cables; and the software on disc with an instruction sheet. There are two versions of the software, one which drives up to 5 units and is faster than the version that will drive up to 32 units.

and the following:

6103557 A cable to connect the units together, one for each unit.

Contact your dealer or Techne Sales for a full list of parts required for your application.

Additional information

Brief fault finding notes and a list of replacement parts are given in this section.

Note that this equipment should only be dismantled by properly trained personnel. **Removing the outer cover exposes potentially lethal mains voltages.**

There are no user serviceable parts within this equipment.

Fault Finding

Should you have any problems with your TC-512 which cannot be easily remedied, you should contact your supplier and return the unit if necessary. Please include details of the fault observed and remember to return the unit in its original packing. Techné accept no responsibility for damage to units which are not properly packed for shipping: if in doubt, contact your supplier, giving the full serial number of the unit and software version number (shown when the unit is first switched on).

Fuses

If neither the power light nor displays on the front panel are lit, one of the two fuses may have blown. Check that there is no external cause, such as a faulty plug or lead. Check both fuses and replace the faulty fuse with a new one of the correct value. (Fuse values are given on the label next to the power inlet.) Note that fuses should only be replaced by a qualified electrician.

The holder for the two fuses is built into the mains input socket. First remove the power cable, then gently prise the fuse drawer open with a flat-bladed screwdriver or similar tool.

Each fuse can be removed by using the screwdriver as a lever.

Exchange the faulty fuse in the fuse holder for a working fuse of the correct value. Finally, replace the fuse drawer in the fuse compartment and push the drawer shut.

Fuses which blow repeatedly indicate a serious fault and you should return the unit to your supplier for repair.

Insulation Testing

This equipment is fitted with RFI suppression circuitry. Any check of the electrical insulation by means of high voltage dielectric testing (for example as in BS EN 61010-1) must be carried out using only a DC voltage.

This unit contains semiconductor components which may be damaged by electric field effects.

Interchangeable blocks

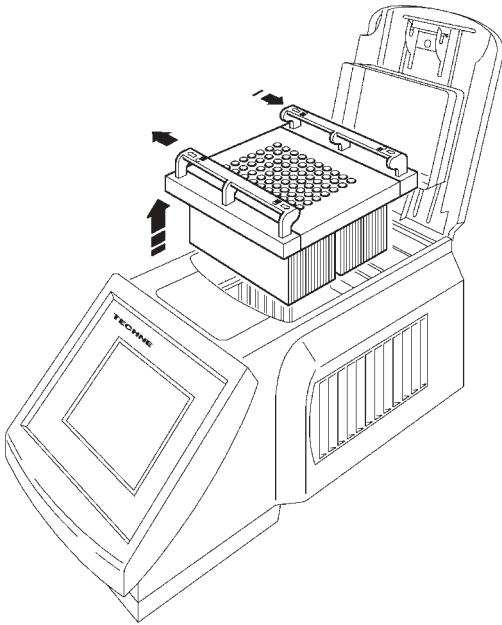

Block removal

Ensure that the unit is turned off and disconnected from mains.

The block can be removed and exchanged for another as required.

Slide the quick release handles in the direction shown above and lift the assembly out of the unit.

Never lift or carry the block by one quick release handle, always use both handles or support the block underneath.

When refitting the block, or fitting a new one, slide the quick release handles in the opposite direction to the above arrows to lock the block assembly into the unit. The software will register the change and calibrate the unit for the new block.

Remember to adjust the options in the Program Defaults Menu for the new application.

If you have fitted the flat block for slide applications you must choose Heated Lid OFF. See the section headed Program Defaults Menu.

Accessories

The following accessories can be obtained from Techne or your Techne dealer:

Item No	Description	Quantity
FTU05TW	0.5ml microtubes, thin wall	Pack of 1000 with caps
FTU02TW	0.2ml microtubes, thin wall	Pack of 1000 with caps
FMITUBC	0.2ml microtubes, thin wall	125 strips of 8
FMICAPC	0.2ml micro tube caps	125 strips of 8
F96T02	96 well plate, flat top non-skirted, pad of 25 plates	pack of 25
F96PLNS	96-well plate raised top non-skirted	Case of 50
F96PLHS	96-well plate half skirt	Case of 50
F96SEAL	96-well sealing mat (silicone)	Case of 50
FTC51BHD	TC-512 block 96 x 0.2ml microtube or 96 well plate	1
FTC51BFD	TC-512 block 96 x 0.2ml microtube or 96 well plate	1
FTC51B5D	TC-512 block 40 x 0.5ml microtube	1
FTC51BID	Flat plate block for in situ (non TC-512)	1
FTC5B384	TC-512 block 384 well plate	1

For full details of "Gensoft" contact your dealer or Techne Sales Department.

Replacement parts

The following replacement parts can be obtained from Techne or your Techne dealer:

Item N°	Description	Quantity required
FCABRTUK	Mains cable and plug UK 230V	1
FCABRTEU	Mains cable and Schuko plug 230V	1
FCABRTUS	Mains cable and US 3-pin plug 120V	1
FCABRTUS	Mains cable and US 3-pin plug 100V	1
6500342	Fuse T6.3A, 230V units	2
6008445	Fuse T8A, 120V units	2
6500324	Fuse T10A, 100V units	2
6104172	Non-Volatile Memory Module	1

Notes